

Metro™ Variable Message Sign



Owner's Manual
September 2015

Contents

- 1 Introduction 1**
 - 1.1 Read before using 1
 - 1.2 Trailer models 1
 - 1.3 Applications..... 1
 - 1.4 Where to obtain service..... 2
- 2 Safety 3**
 - 2.1 Safety statements in this manual..... 3
 - 2.2 General safety 4
 - 2.3 Operating safety..... 4
 - 2.3.1 Prior to use 4
 - 2.3.2 During operation 5
 - 2.4 Service safety 6
 - 2.5 Labels..... 7
- 3 Assembly 9**
- 4 Operation 11**
 - 4.1 Overview..... 11
 - 4.2 Before using the message sign..... 11
 - 4.3 Towing..... 12
 - 4.3.1 Before towing 12
 - 4.3.2 During towing..... 15
 - 4.3.3 After towing 15
 - 4.4 Deployment..... 16
 - 4.4.1 Locating and positioning the trailer 16
 - 4.4.2 Leveling the trailer..... 17
 - 4.4.3 Raising the display and setting a message 18
 - 4.4.4 Using the controller..... 20
 - 4.4.5 Batteries..... 20
 - 4.5 Optional equipment..... 21
 - 4.5.1 Cellular modem..... 21
 - 4.5.2 Radar..... 21
 - 4.5.3 Traffic Data Classifier System 22

5	Troubleshooting	23
5.1	Before troubleshooting	23
5.2	Alarms	23
5.2.1	Display alarm	24
5.2.2	Power board alarm	25
5.2.3	NTCIP alarm	26
5.2.4	AuxIO alarm	26
5.2.5	Voltage alarm	27
5.2.6	Temperature alarm	27
5.2.7	Photocell alarm	28
5.3	Main terminal strip	30
5.4	Message display	31
5.5	Controller	32
5.6	Power failure	33
5.7	Radar	34
5.7.1	Before troubleshooting radar	34
5.7.2	Radar troubleshooting procedure	34
6	Maintenance	37
6.1	Periodic maintenance	37
6.2	Display cabinet	38
6.2.1	Polycarbonate window	38
6.2.2	Photocells	38
6.2.3	Display modules	39
6.3	Power system	40
6.3.1	Overview	40
6.3.2	Solar panels	40
6.3.3	Batteries	40
6.4	System reset	46
6.5	Software update	46
6.6	Storing the message sign	47
6.7	Winch cable replacement	48
6.8	Wiring	48
6.9	Replacement parts	48

List of Figures

Figure 1-1	Vehicle identification tag	2
Figure 2-1	Label locations	7
Figure 3-1	Wiring and harness	9
Figure 3-2	Drawbar installation	9
Figure 4-1	Before towing	13
Figure 4-2	Tow-chain hook-up	15
Figure 4-3	Positioning the trailer	17
Figure 4-4	Deploying the sign	19
Figure 4-5	Sight-tube	20
Figure 5-1	Power board wiring connections	26
Figure 5-2	Photocells and main terminal strip	29
Figure 5-3	Fuses on the power board	34
Figure 5-4	Radar wiring connections and fuses	35
Figure 5-5	Radar wiring terminals	35
Figure 6-1	Reset button and USB port on computer box	47
Figure 6-2	Trailer wiring	49
Figure 6-3	Display cabinet wiring	50
Figure 6-4	Battery box wiring	52
Figure 6-5	Replacement parts: trailer assembly	53
Figure 6-6	Replacement parts: tower assembly	54
Figure 6-7	Replacement parts: display cabinet assembly	55
Figure 6-8	Replacement parts: drawbar assembly	56
Figure 6-9	Replacement parts: battery box assembly	57

List of Tables

Table 2-1	Label samples and descriptions	7
Table 5-1	Alarms indicated by the controller	23
Table 5-2	Power values	27
Table 5-3	Temperature values	27
Table 5-4	Troubleshooting a blank display	31
Table 5-5	Troubleshooting messages that appear or disappear unexpectedly	31
Table 5-9	Troubleshooting inoperable controller	32
Table 5-6	Troubleshooting partial messages and duplicate characters	32
Table 5-7	Troubleshooting stuck LEDs	32
Table 5-8	Troubleshooting LED brightness problems	32
Table 5-10	Troubleshooting automatic shutdown	33
Table 5-11	Troubleshooting power problems	33
Table 6-1	Battery charge requirements	43

1 Introduction

1.1 Read before using

This is the owner's manual for the Wanco® Metro™ Variable Message Sign.

For your safety and protection from injury, carefully read, understand, and observe all instructions in this manual. Always read all instructions before performing a procedure.

Keep a copy of this manual with the message sign. Additional and replacement manuals are available from the factory (see Section 1.4, "Where to obtain service," page 2).

If you have questions regarding this product, please contact Wanco Service or Sales using the information in Section 1.4.

1.2 Trailer models

The Wanco Metro Message Sign is available with either of two display cabinet sizes: large and medium. The trailer is the same for both sign sizes, and there is no difference in operation regardless of sign size.

The large display cabinet is available with optional color display modules. The standard sign has only amber display modules. The sign operates the same regardless of the display modules.

1.3 Applications

Wanco designed the Metro Message Sign for use in metropolitan areas and wherever trailer size is a concern. Metro signs provide the same visibility and legibility as other Wanco message signs, but with a smaller footprint.

Common uses for Metro signs include urban areas where a sidewalk is the only place to put a message sign, congested streets where a full-size sign might impede traffic, and anywhere a full-size sign is not practical. These signs are used every day for traffic safety, emergency response, and special events.

Because of its compact size, the Metro trailer is easy to maneuver and deploy, particularly where traffic is heavy or space is limited. For optimal positioning, the display cabinet rotates independent of the trailer, and its height is fully adjustable. Power is provided by batteries and an automated solar charging system.

Metro signs use the Wanco touchscreen controller, which features a high-resolution, full-color interface. The touchscreen provides access to all the functions of the standard Wanco message-sign interface. For instructions, see the controller user-interface manual.

1.4 Where to obtain service

Before calling for service, please have the unit's model number and VIN ready. This information is displayed on the vehicle identification tag (see Figure 1-1).

Contact our service department using the following information:

Wanco Inc.

5870 Tennyson Street
Arvada, Colorado 80003 USA

303-427-5700
fax 303-427-5725

www.wanco.com
info@wanco.com

Figure 1-1. Vehicle identification tag

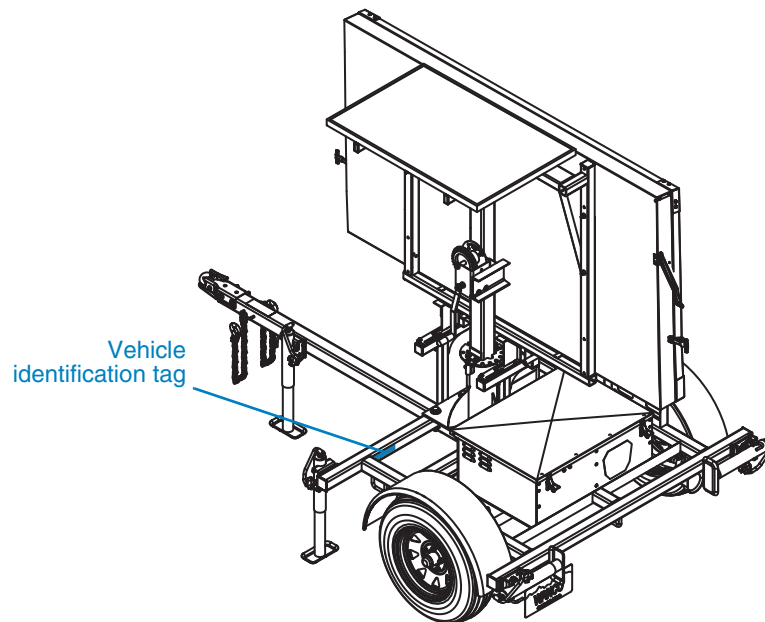

2 Safety

2.1 Safety statements in this manual

This manual contains the following types of callouts, which must be followed to reduce the possibility of personal injury, damage to the equipment, or improper service. Each alert has a specific meaning, as described below:

 The safety alert symbol alerts you to potential personal injury hazards. Obey all safety messages that follow this symbol to avoid possible injury or death.

DANGER

Indicates an imminently hazardous situation which, if not avoided, WILL result in death or serious injury.

WARNING

Indicates an imminently hazardous situation which, if not avoided, COULD result in death or serious injury.

CAUTION

Indicates a potentially hazardous situation which, if not avoided, could result in minor or moderate injury.

CAUTION

Used without the safety alert symbol, indicates a potentially hazardous situation which, if not avoided, could result in property damage.

IMPORTANT!

Indicates information that is of particular importance when transporting, operating, or servicing the equipment.

2.2

General safety



⚠ WARNING

Improper use of equipment could cause serious injury or death.

Prior to using this product, carefully read, understand, and observe all instructions in this manual.



⚠ CAUTION

Crush hazard.

When operating or working on the message sign, keep hands and body parts clear of pinch points.

2.3

Operating safety

2.3.1

Prior to use

- To reduce the risk of personal injury, ensure the surrounding area is in good order and free of debris.
- To reduce the risk of shifting, rolling, or overturning, locate the message sign on a firm, level surface.



⚠ WARNING

Falling equipment could cause severe injury or death.

Before raising display cabinet, stabilize and level the trailer.

- Always stabilize and level the trailer before raising the display cabinet.
- Ensure the message sign is in good operating condition. Never use any equipment that is damaged or in need of repair.

2.3.2

During operation



⚠ WARNING

Loose equipment can cause severe injury.

Ensure wind does not catch and unexpectedly rotate unlocked display cabinet.



⚠ WARNING

Improper sign display could cause a traffic accident resulting in severe injury or death.

Visually inspect message sign to ensure correct message is displayed.

- When deploying the sign in windy conditions, ensure the display cabinet rotation is locked to prevent the wind from catching and unexpectedly rotating the cabinet.
- Always visually inspect the message on the sign to ensure the sign is operating as expected. Always replace display modules that are not operating.
- Never move the message sign trailer while the display cabinet is raised.
- Do not allow water to accumulate around the base of the trailer.
- When the mast and display cabinet are raised, verify the height locking-pin is engaged.

2.4

Service safety

**WARNING****Fire hazard.**

When working with the message sign batteries, never allow positive wiring to short to ground.

**CAUTION****Adverse weather conditions can cause equipment damage and injury.**

Whenever possible, perform maintenance indoors or in calm, dry weather.

CAUTION**Voltage surge could damage control circuits.**

Before servicing electrical components, disconnect power cable from computer box.

- Always take precautions to ensure the safety of service personnel. Whenever possible, perform maintenance indoors, out of the weather and away from traffic.
- Never perform any service unless all electrical components are shut down. Ensure all message sign power circuits are shut off.
- Always disconnect power cable from computer box before disconnecting battery cables. The computer box is located inside the battery box.
- If disconnecting message sign battery cables, always disconnect the positive (+) cable first.* Do not allow positive power cable to short to ground.
- If the ground under or around the trailer is damp or wet, move the trailer to a dry location and allow it to dry before servicing.
- Do not service the message sign if your clothing or skin is wet.
- Always be aware of traffic when performing roadside maintenance.
- Keep the message sign and all its components clean.

**Removing the positive cable first is a requirement for negative-ground systems.*

2.5 Labels

Labels provide instructions and information. They also warn of hazards. For convenience and safety, keep all labels in legible condition, replacing them when they are damaged or missing. Replacement labels are available from the factory.

Label locations are indicated in Figure 2-1. Samples of labels and their descriptions are provided in Table 2-1.

Figure 2-1. Label locations

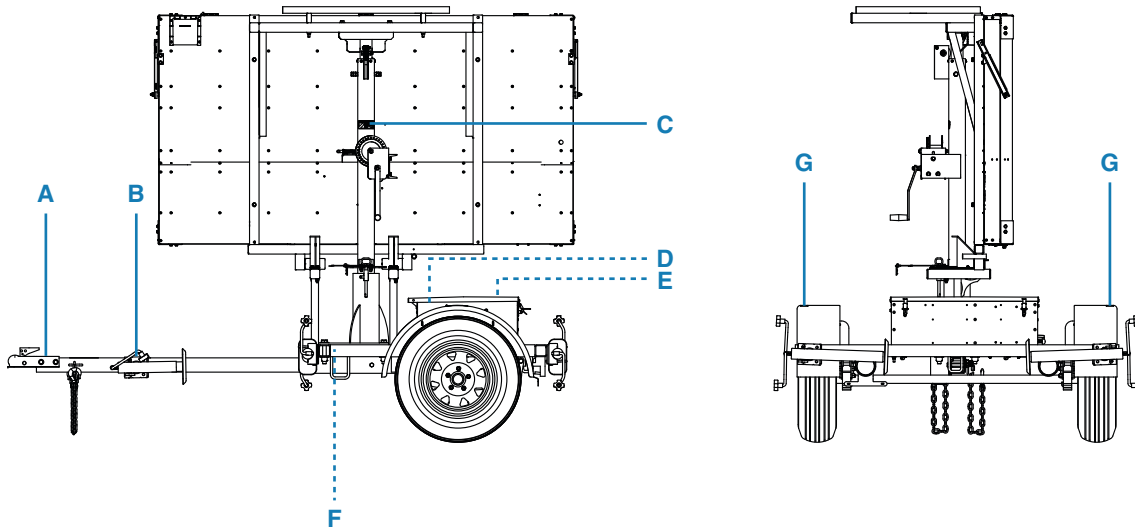
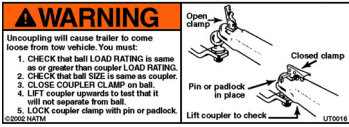

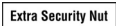
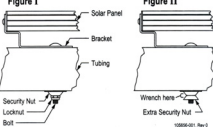



Table 2-1. Label samples and descriptions

Ref.*	Label (not to scale)	Description
A		Warning: towing connection
B		Caution: extend stabilizing jack
C		Release locking-pin
D		Extra security nut

*Reference Figure 2-1 for label location.

Table 2-1. Label samples and descriptions *continued*

Ref.*	Label (not to scale)	Description
E	<p style="text-align: center;">Solar Panel Bracket Security Nuts</p> <p>Removal:</p> <ul style="list-style-type: none"> - Remove the extra security nut from the bottom of this box. - Remove the locknut from the bracket bolt (Figure I). - Hand install the extra security nut onto the bracket bolt as shown (Figure II). - Remove both security nuts with a 7/8" wrench. - Repeat for the remaining three bolts. <p>Reinstallation:</p> <ul style="list-style-type: none"> - Reverse procedure to reinstall the security nut and locknut (Figure I). - When finished, reinstall the extra security nut to the bottom of the box. 	Solar panel bracket security nuts
F	<p>MANUFACTURED BY / FABRIQUE PAR: _____ DATE _____</p> <p>GWR / PNBV _____ KG (_____ LB) _____ KG (_____ LB) TIRES / PNEU _____</p> <p>RIMS / JANTE _____</p> <p>COLD INFL. PRESS. / PRESS. DE GONFL. A FROID _____ KPA (_____ PSI / LPSI) <input type="checkbox"/> SINGLE <input type="checkbox"/> DUAL</p> <p><small>THIS VEHICLE CONFORMS TO ALL APPLICABLE U.S. FEDERAL MOTOR VEHICLE SAFETY STANDARDS IN EFFECT ON THE DATE OF MANUFACTURE SHOWN ABOVE. THIS VEHICLE CONFORMS TO ALL APPLICABLE STANDARDS PRESCRIBED UNDER THE CANADIAN MOTOR VEHICLE SAFETY REGULATIONS IN EFFECT ON THE DATE OF MANUFACTURE. CE VEHICULE EST CONFORME A TOUTES LES NORMES QUI LUI SONT APPLICABLES EN VERTU DU REGLEMENT SUR LA SECURITE DES VEHICULES AUTOMOBILES DU CANADA EN VIGUEUR A LA DATE DE SA FABRICATION.</small></p> <p>V.I.N. / N.I.L.V.: _____ TYPE / TYPE: TRAILER TRM / REM _____ FD-306 REV A</p>	Vehicle identification tag
G		Caution: not a step

*Reference Figure 2-1 for label location.

3 Assembly

Before using your Wanco Metro Message Sign for the first time, it might be necessary to install the drawbar. The drawbar may be removed before shipment from the factory. To install the drawbar, follow these steps:

1. The drawbar includes wiring for the trailer lights. Before installing the drawbar, ensure the wiring and harness are hanging out of the drawbar, as indicated in Figure 3-1.
2. Refer to Figure 3-2 and install the drawbar and wiring:
 - a. Locate the receiving sleeve, centered under the trailer frame.
 - b. Carefully insert the wiring and harness into the sleeve, followed by the drawbar.
 - c. Align the holes in the sleeve and drawbar.
 - d. Attach the drawbar to the trailer with two sets of bolts, washers, and nuts. Tighten the nuts fully.
 - e. Connect the wiring harness to the receptacle under the trailer frame. Before towing, ensure the trailer brake lights, taillights, and directional/turn indicators are functioning properly.

Figure 3-1. Wiring and harness

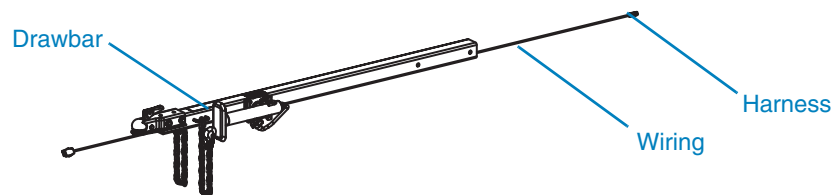
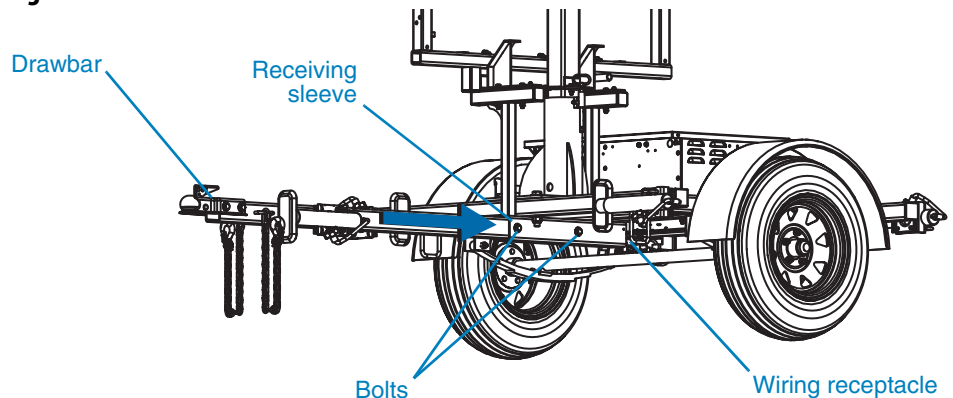

Figure 3-2. Drawbar installation



4 Operation

4.1 Overview

A typical deployment of the Wanco Metro Message Sign includes the following steps:

1. Towing the trailer to its destination (Section 4.3)
2. Locating and positioning the trailer (Section 4.4.1, page 16)
3. Leveling the trailer (Section 4.4.2, page 17)
4. Raising the display cabinet and setting a message (Section 4.4.3, page 18)

4.2 Before using the message sign

Before using the Wanco Metro Message Sign:

- Read and follow all safety instructions (see Section 2, page 3).
- Ensure batteries are fully charged (for charging instructions, see Section 4.4.5, page 20).
- If the message sign is being returned to service after being in storage, check the cables inside the battery box to ensure they are connected. When reconnecting cables, follow these steps:
 1. Ensure power cable is not connected to the computer box, which is located inside the battery box. If it is connected, disconnect it before connecting battery cables.

CAUTION



Voltage surge could damage control circuits.

Before connecting battery cables, ensure power cable is disconnected from computer box.

2. Taking care not to over-tighten the cable clamps:
 - a. Connect the negative (-) cable to the battery.
 - b. Connect the positive (+) cable to the battery.
3. Connect message sign cable to computer box, if it is not already connected.
4. Connect power cable to computer box.

For additional information:

- Instructions for using the controller to operate the message sign are provided in the controller user-interface manual.
- Instructions for creating custom messages are provided in the Wanco Message Graphics software manual.

4.3

Towing

4.3.1

Before towing

Before towing, refer to Figure 4-1 and prepare the message sign as follows:

1. Use the controller, located in the battery box, to “blank” the message sign. (For instructions, see the controller user-interface manual.)
2. Close and latch the battery box. Do not lower the display cabinet while the battery box is open.
3. Lower the mast and display cabinet into the travel position:
 - a. Pull and hold the height locking-pin to release the mast so that it can be lowered.



DANGER

Falling equipment will cause severe injury or death.

If height locking-pin is stuck, removing the pin may cause the display cabinet to fall.

- Do not force pin.
- Contact factory for assistance.

- b. While holding the pin, use the hand-operated winch to start lowering the mast and cabinet. As they begin to come down, release the pin.
- c. Lower the mast until the bottom edge of the display cabinet is within easy reach. Do not lower it all the way yet.
- d. Pull the rotation locking-pin to release the mast so that it can be turned.



WARNING

Loose equipment can cause severe injury.

Ensure wind does not catch and unexpectedly rotate unlocked display cabinet.

- e. Rotate the cabinet so that the sign support legs are over the travel cradles.
- f. Use the winch to lower the sign support legs into the travel cradles. When lowered all the way, the height locking-pin snaps into place with an audible “click,” locking the cabinet in the down position.
- g. Reinsert the rotation locking-pin.

Figure 4-1. Before towing

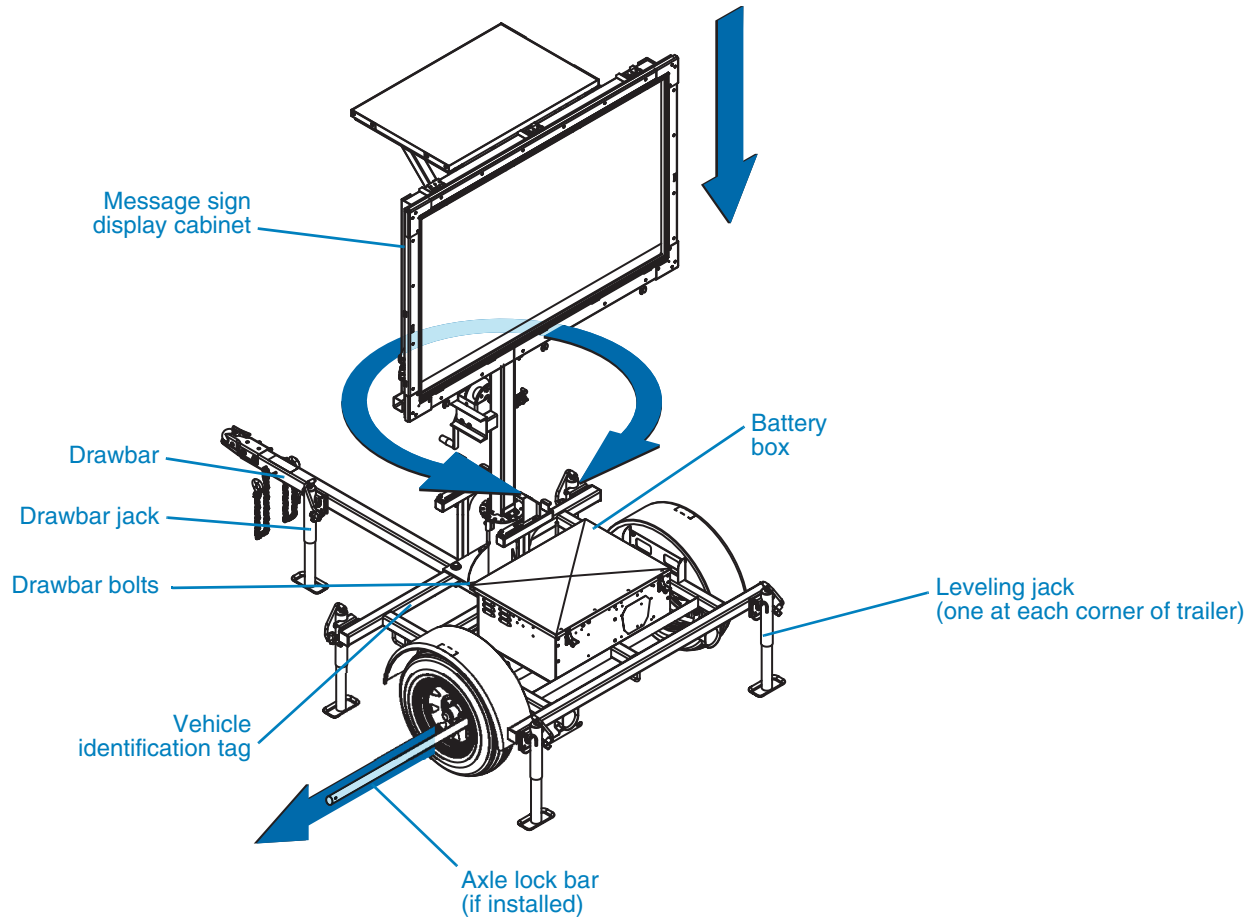

Detail view

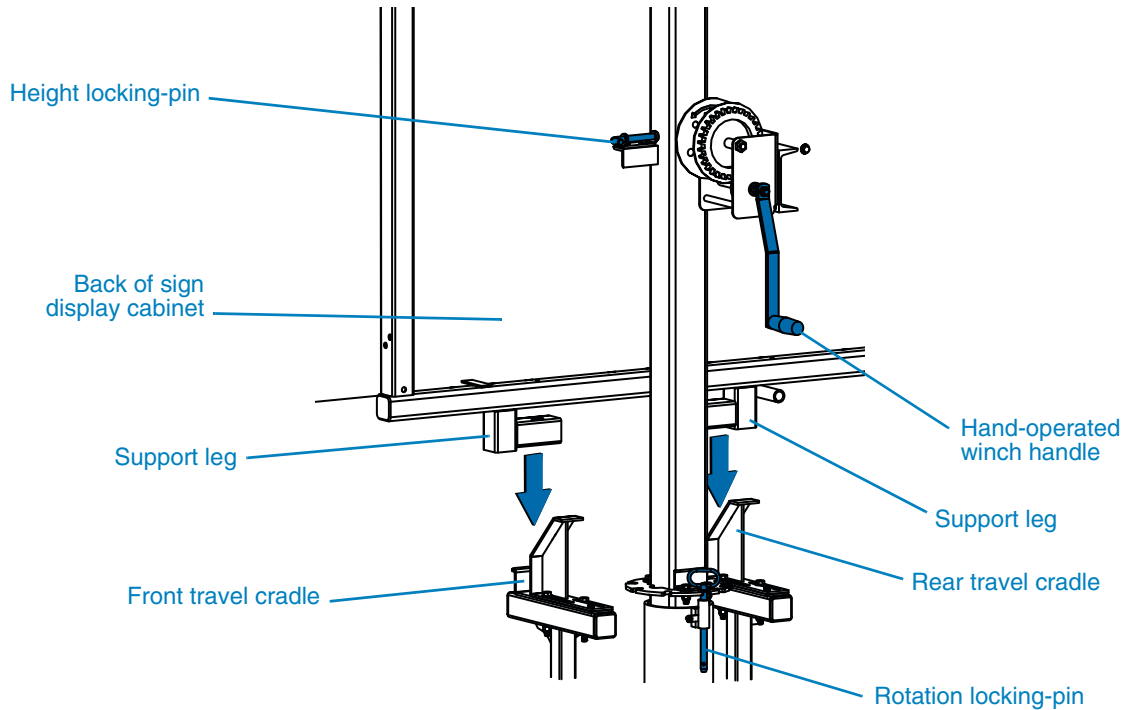

4. Check tires, wheels, and axle lock:
 - a. Check tires for wear. Replace worn tires.
 - b. Ensure tires are inflated to the proper pressure.
 - c. Verify all wheel lugs are in place and tightened. Do not tow the trailer if a wheel lug is missing.
 - d. Remove the axle lock bar, if installed.
5. Check the drawbar, tow hitch, and safety chains:
 - a. Ensure the tow hitch on the tow vehicle is rated for weight equal to or greater than the message sign's gross vehicle weight rating (GVWR). The GVWR is listed on the vehicle identification tag.
 - b. Ensure the tow hitch on the tow vehicle and the drawbar hitch on the message sign trailer are compatible.
 - c. Inspect the tow hitch and drawbar hitch for wear and damage. Replace or repair if necessary.
 - d. Ensure the trailer's removable drawbar is attached securely to the trailer frame with two sets of bolts, washers, and nuts. The bolts should engage the drawbar and the nuts should be tight. (For drawbar installation instructions, see Section 3, page 9.)
 - e. Lower the drawbar jack into the down position by pulling the jack locking-pin and rotating the jack downward. Release the pin and continue rotating the jack until it is vertical. When the jack is properly set, the locking-pin snaps into position with an audible "click." Use the hand-crank on the jack to lower the jack foot to the ground.
 - f. Verify the trailer's four corner leveling jacks are in the up position and secured with their locking-pins. To raise the leveling jacks, use the hand-crank on each jack to raise the jack foot off the ground, then pull the jack locking-pin and rotate the jack upward. Release the pin and continue rotating the jack until it is horizontal and the pin reengages with an audible "click."
 - g. Use the drawbar jack to raise the front of the trailer and set the drawbar hitch on the tow vehicle hitch. Ensure the coupling is properly engaged and locked.
 - h. Raise, rotate, and lock the drawbar jack in the up or horizontal position.
 - i. Verify approved safety chains are attached properly to both the trailer and tow vehicle, as illustrated in Figure 4-2. The chains should cross underneath the tow hitch.
6. Ensure the trailer brake lights, taillights, and directional/turn indicators are connected and functioning properly.
7. Remove blocks or chocks from wheels.
8. Follow the towing requirements in Section 4.3.2.

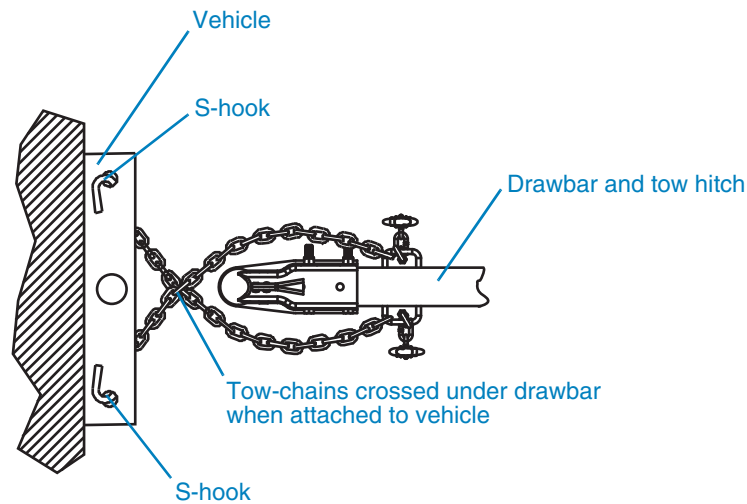
Figure 4-2. Tow-chain hook-up

4.3.2

During towing

- Do not tow the trailer with any people, parts, supplies, or additional equipment attached to the trailer or loaded onto it.
- Do not tow additional trailers or other equipment in tandem with the message sign trailer.
- The recommended maximum speed for highway towing is 65 mph (105 km/h). For off-road towing, the recommended maximum speed is 15 mph (25 km/h) or less, depending on terrain.
- Adhere to applicable transportation department regulations when towing the trailer.

4.3.3

After towing

- After towing, unhook the tow chains from the tow vehicle, then use the drawbar-mounted jack to raise the drawbar and release the drawbar hitch from the tow vehicle. Pull the vehicle away from the message sign trailer when ready.
- If desired, the drawbar may be removed from the trailer.
 - Before removing the drawbar, level the trailer as instructed in Section 4.4.2, page 17.
 - To remove the drawbar, disconnect the wiring harness from the trailer, loosen and remove the two bolts that connect the drawbar to the trailer, then remove the drawbar by sliding it forward.
 - To prevent the nuts and bolts from being lost, insert the bolts into the holes on the trailer and secure them and the washers in place with the nuts.

4.4 Deployment

4.4.1 Locating and positioning the trailer



⚠ DANGER

Electric shock hazard.

Contact with overhead electrical power lines will cause serious injury or death.

Do not position message sign under power lines.

- When deployed, the message sign mast rises to over 11 feet (3.4 meters). When choosing a location, ensure the area above the trailer is clear of overhead wires and other obstructions.
- To reduce the risk of shifting, rolling, or overturning, locate the message sign on a firm, level surface.
- Depending on vehicle speed, optimal positioning provides a line-of-sight from 500 to 1000 feet (155 to 310 meters), which allows ample time for drivers to read and react to the message on the sign.
- Fog, rain, snow, and blowing dust can reduce the detection distance from drivers to the sign. Allow for possible weather conditions when selecting a location.
- For the message sign's solar charging system to function properly, locate the trailer where it will be exposed to full sunlight during daylight hours.
 - The solar panel charging capacity is significantly affected by shadows. Avoid locating the trailer where the sun will be obstructed, such as under a tree or in the shadow of a building.
 - Ensure the solar panels are clean (see Section 6.3.2, page 40).
- Position the trailer so the rear of the trailer faces oncoming traffic.
- Angle the message sign display slightly toward the roadway (see Figure 4-3).
 - Too great an angle creates a short viewing distance, and does not allow drivers enough time to see the display.
 - A slight angle provides a long viewing distance, and gives drivers plenty of time to see the display.

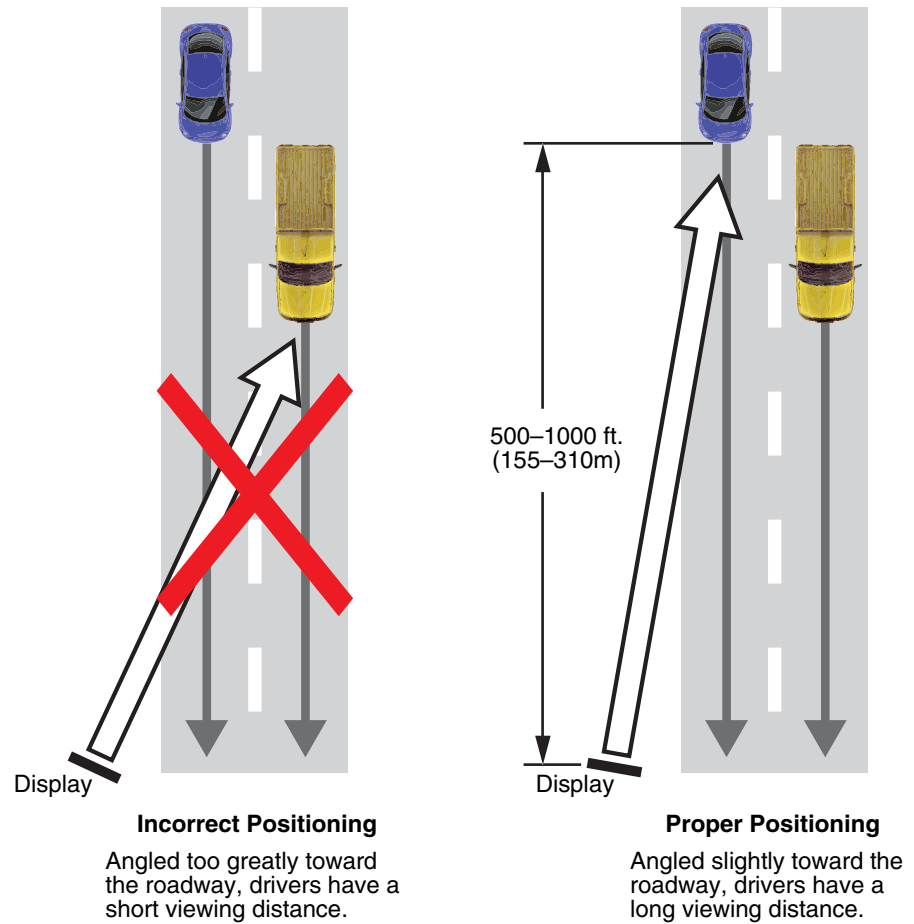
Figure 4-3. Positioning the trailer

4.4.2

Leveling the trailer

Prior to raising the message sign display cabinet, the trailer must be level.

To level the trailer, refer to Figure 4-4 and follow these steps:

1. Block or chock the trailer wheels.
2. For each of the four leveling jacks at the corners of the trailer, pull the jack locking-pin and rotate the jack downward. Release the pin and continue rotating the jack until it is vertical. When the jack is properly set, the locking-pin snaps into position with an audible “click.”
3. Determine which corner of the trailer is highest, and extend the jack foot on that corner downward until it rests firmly on the ground. Then, level the trailer with the remaining three corner jacks and, if desired for added stability, the drawbar jack.

4.4.3

Raising the display and setting a message

After positioning the trailer (Section 4.4.1) and leveling the trailer (Section 4.4.2), raise the sign display and set up the message by referring to Figure 4-4 and following these steps:



WARNING

Falling equipment could cause severe injury or death.

Before raising display cabinet, stabilize and level the trailer.

1. Pull the height locking-pin to release the display cabinet so that it can be raised. While holding the pin, use the hand-operated winch to start raising the cabinet. As the cabinet begins to rise, release the pin.
2. Raise the cabinet until the sign support legs are clear of the travel cradles. Do not raise it all the way yet.
3. Remove the rotation locking-pin to release the mast so the cabinet can be turned.



WARNING

Loose equipment can cause severe injury.

Ensure wind does not catch and unexpectedly rotate unlocked display cabinet.

4. Rotate the cabinet clockwise, so that the front of the display faces traffic.
5. Look toward traffic through the sight-tube and angle the display appropriately (see Figure 4-5, page 20).
6. Insert the rotation locking-pin, locking the angle of the mast and display.
7. Use the winch to raise the mast and display cabinet to the desired height. When raised all the way, the height locking-pin snaps into place with an audible “click,” locking the cabinet in the up position.
8. Using the controller, which is located in the battery box, configure the message that will be displayed on the sign. (For instructions, see the controller user-interface manual).
9. Observe safety precautions (see Section 2, page 3).

Figure 4-4. Deploying the sign

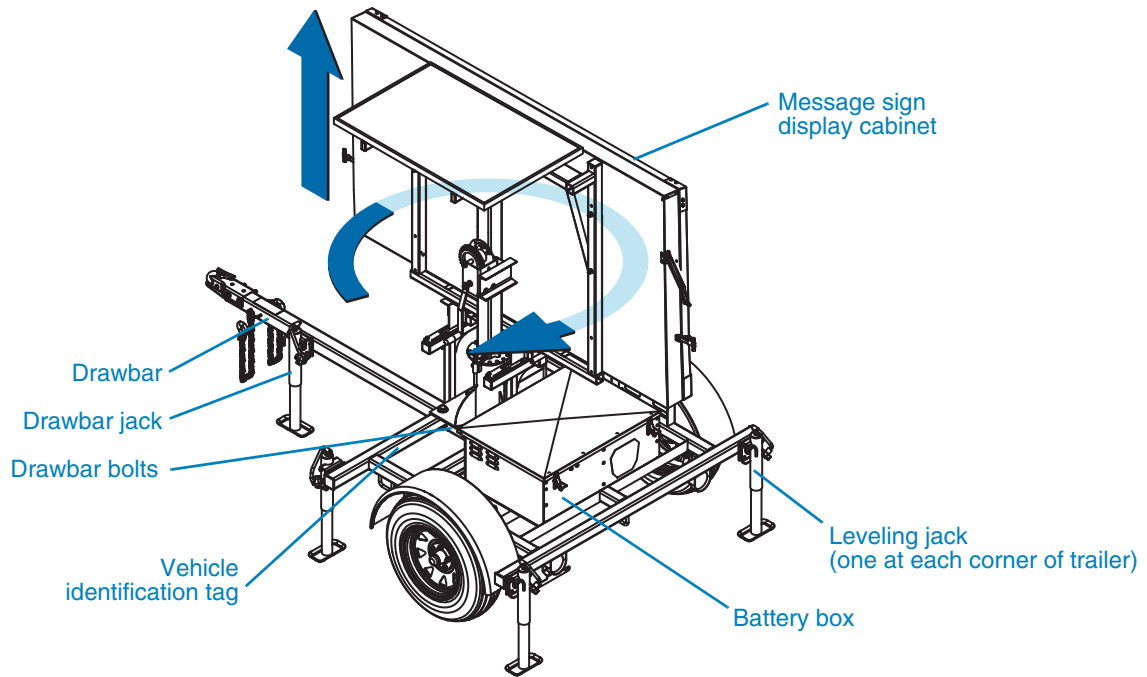

Detail view

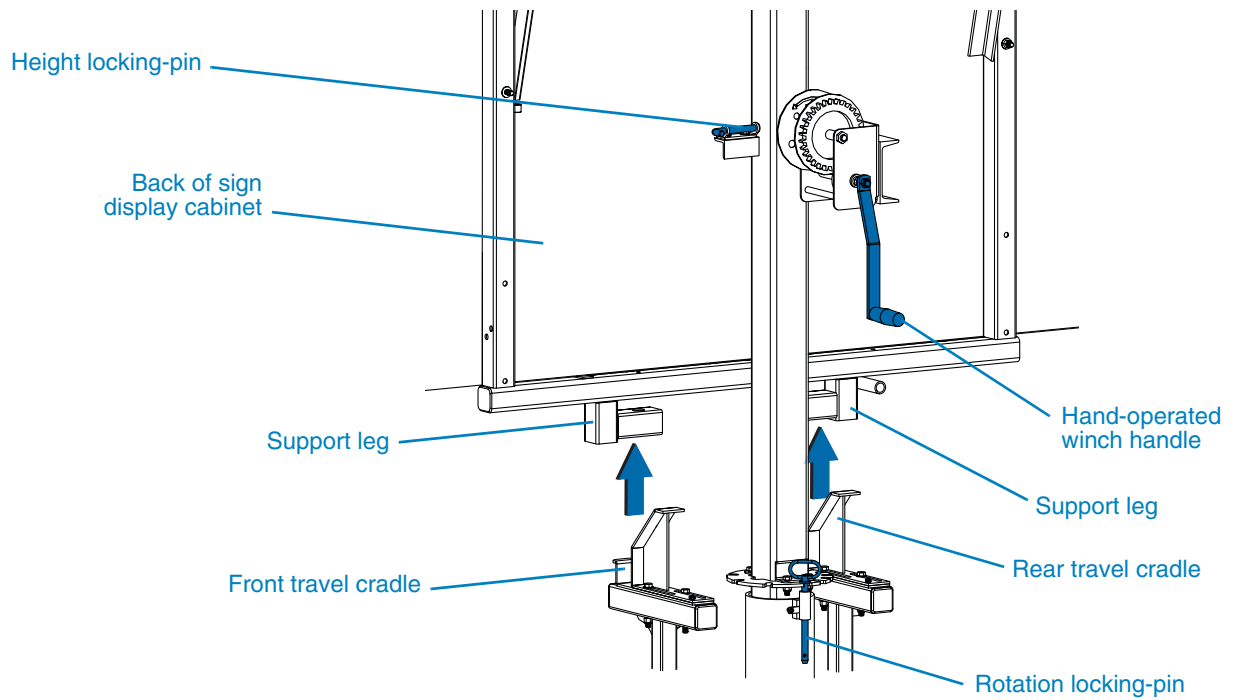
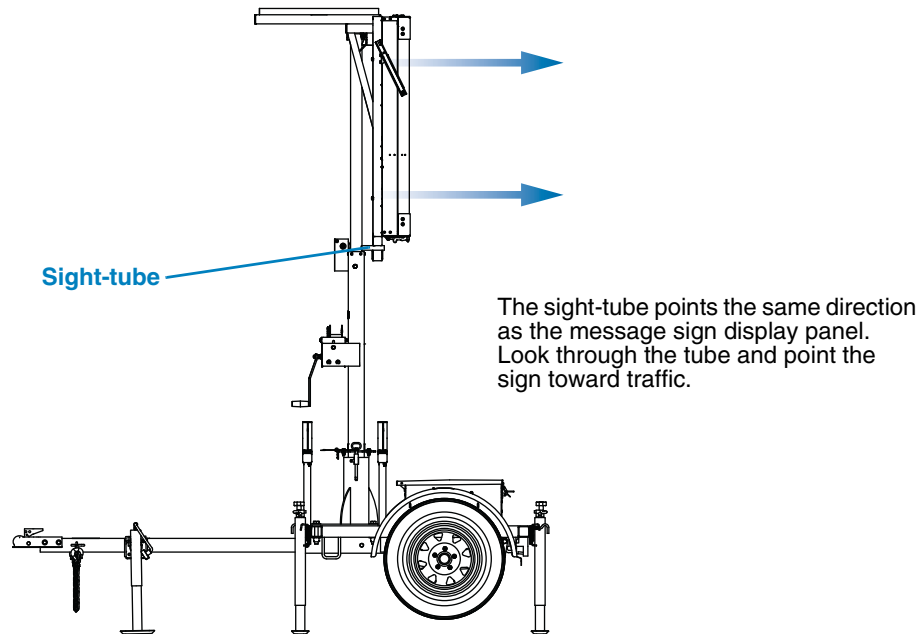

Figure 4-5. Sight-tube



4.4.4

Using the controller

The message sign is equipped with a controller, located inside the battery box. The controller provides access to all sign functions, including configuration, status, and diagnostics. For additional information and instructions, see the controller user-interface manual.

WARNING



Improper sign display could cause a traffic accident resulting in severe injury or death.

Visually inspect the message sign to ensure the correct message is displayed.

4.4.5

Batteries

To ensure battery health, follow these requirements:

- Do not allow batteries to fully discharge.
- Ensure batteries are fully charged before using the message sign.
- Charge batteries after each period of use, before putting the message sign into temporary or long-term storage.
- Power to the message sign is on at all times, and can only be stopped when the batteries are disconnected. Therefore, it is important to “blank” the message sign when it is not in use. (For instructions, see the controller user-interface manual.)
- For an overview of the message sign power system, see Section 6.3.1, page 40.
- For battery charging information, see Section 6.3.3, page 40.

4.5 Optional equipment

4.5.1 Cellular modem

A cellular modem allows you to communicate with the sign from a remote location via the Internet. The modem is installed inside the control box and is wired to the message sign computer.

If your sign has a modem, you can use Wanco remote control software installed on your computer to perform all the functions from a remote location that you would otherwise perform using the controller and keyboard at the sign. The modem does not allow remote control of the message sign winch.

Wanco remote control software can be downloaded from www.wanco.com. Contact the Wanco Customer Service Department for details (see Section 1.4, page 2).

The cellular modem is optional, auxiliary equipment that may not be included with your message sign.

If you want to add a modem to your sign, it can be installed in the field. Contact the Wanco Customer Service Department for details (see Section 1.4, page 2).

4.5.2 Radar

When a message sign is equipped with speed-detection radar, the sign can be configured to display messages based on the speed of passing vehicles. The radar head is installed on the bottom of the message sign display cabinet and is wired to the message sign controller.

The message sign is preprogrammed with several messages that use radar-detected speed (such as displaying the motorist's speed), and you can also program your own radar-based messages by inserting a specific "field code" into your message. For instructions, see the controller user-interface manual.

Radar is optional, auxiliary equipment that may not be included with your message sign.

If you want to add radar to your sign, it can be installed in the field. Contact the Wanco Customer Service Department for details (see Section 1.4, page 2).

4.5.3 Traffic Data Classifier System

The Wanco Traffic Data Classifier system collects traffic data at the message sign, and lets you classify that data for analysis using Wanco computer software. The data collector is installed on the bottom of the message sign display cabinet and is wired to the message sign computer.

The data collector employs side-fire radar to measure vehicle speed and length. It saves this information, along with the date and time, in a log file that can be downloaded to a computer. Wanco's Data Classifier software interprets and graphs the data for analysis. Instructions are included with the system.

Wanco Data Classifier software can be downloaded from www.wanco.com. Contact the Wanco Customer Service Department for details (see Section 1.4, page 2).

The Traffic Data Classifier System is optional, auxiliary equipment that may not be included with your message sign.

If you want to add the Traffic Data Classifier System to your sign, it can be installed in the field. Contact the Wanco Customer Service Department for details (see Section 1.4, page 2).

5 Troubleshooting

5.1 Before troubleshooting

Before performing any troubleshooting or servicing on the message sign, observe all safety precautions in Section 2, page 3.



CAUTION

Voltage surge could damage control circuits.

Before servicing electrical components, disconnect power cable from computer box.

Always disconnect power cable from computer box before disconnecting battery cables. The computer box is located inside the battery box.

When using the message sign controller for troubleshooting, refer to the controller user-interface manual for additional information if necessary. The user-interface manual is included with the message sign and may also be downloaded from www.wanco.com.

IMPORTANT!

You must have advanced- or service-level access to the controller in order to perform service and troubleshooting procedures.

5.2 Alarms

The controller may display any of the active alarms listed in Table 5-1, which can indicate issues with the message sign that require attention.

Table 5-1. Alarms indicated by the controller

Alarm	Description	Solution
Dsply=!!	One or more sign display modules not responding	see Section 5.2.1, page 24
PwrBd=!!	Power control system not responding	see Section 5.2.2, page 25
NTCIP=!!	NTCIP system communications error	see Section 5.2.3, page 26
AuxIO=!!	Communications error between the sign and one or more auxiliary devices	see Section 5.2.4, page 26
VoltWrn=!!	One or more voltages out of range	see Section 5.2.5, page 27
TempWrn=!!	One or more temperatures out of range	see Section 5.2.6, page 27
TempCrt=!!	Sign temperature is critically high and the sign display has been “blanked”	see Section 5.2.6, page 27
PhtoCel=!!	One or more photocell inputs are out of range	see Section 5.2.7, page 28

5.2.1

Display alarm

A display alarm indicates one or more of the sign's display modules are not responding properly. When a display alarm occurs, use the controller to run a diagnostic test on the display modules.

If any module appears to be functioning improperly, or if LEDs fail to light, perform the following steps to determine the cause. If no LEDs on a display module will light (i.e., the module appears not to be working), the cause could be faulty wiring or a loose connection.

IMPORTANT!

If more than one module is malfunctioning, always address "upstream" modules first, working from left to right and top to bottom. When several modules exhibit problems, it may be due to the first module in the sequence.

When a display alarm occurs:

1. Follow the safety requirements in Section 2, page 3.
2. Identify the malfunctioning display module and one that appears to be working properly. Remember their locations.
3. Use the controller to "blank" the message sign.
4. Open the display cabinet door (which is hinged at the top and latched on the sides and the bottom).
5. Before replacing a module, check its wiring connections:
 - a. Identify the malfunctioning module and locate the four retaining nuts that hold it in place.
 - b. Using the supplied nut wrench or a 5/16-inch nut driver, remove the four nuts.
 - c. Carefully pull the display module away from the cabinet to expose the wiring connections on back of the module. The wiring can be damaged if you use too much force.
 - d. Check that the wiring connections are secure and properly connected.
6. If the connections are secure, remove two modules and switch their positions:
 - a. Being careful to avoid using too much force, first unplug the power connector on back of the malfunctioning display module by pulling the connector straight out, away from the module; then unplug the data input wires by pushing the locking tab down and pulling the plug sideways, away from the connector. Repeat for the data output wires. (The bottom-right module does not have output wiring.)
 - b. Set the malfunctioning display module aside.
 - c. Repeat the process to remove a properly functioning display module.
 - d. Reverse the procedure to install the functioning module where the malfunctioning module used to be, then install the malfunctioning module where the properly functioning module used to be.

7. Use the controller to access the display module diagnostics, then initialize the message sign and start a new self-test. After initialization is complete:
 - If the functioning module is not working, then the problem is with the wiring. Contact the factory for assistance (see Section 1.4, “Where to obtain service,” page 2).
 - If the malfunctioning module is not working in its new position, the problem is with the module, not the wiring. Replace it as described below.
8. To replace the malfunctioning display module:
 - a. Use the controller to “blank” the message sign.
 - b. Disconnect the wiring from the malfunctioning display module and remove the module from the display cabinet.
 - c. Set the malfunctioning display module aside.
 - d. Reverse the procedure to install a new, replacement display module.
9. Use the controller to access the display module diagnostics, then initialize the message sign and start a new self-test.
10. After initialization is complete, use the controller to put a test message on the sign, and ensure the sign is working as expected.
11. When done, close and latch the display cabinet door.

5.2.2

Power board alarm

A power board alarm indicates the sign’s computer is not communicating with the power control system. The cause may be a bad connection, or a failed power board or main control board.

When a power board alarm occurs:

1. Follow the safety requirements in Section 2, page 3.
2. Check wiring connections to ensure they are proper and secure (see Figure 5-1). If a problem with the connection or cable is obvious, replace the cable; otherwise, unplug each connector and plug it back in.
3. Check the controller for alarms or status.
4. If the problem persists, contact the factory (see Section 1.4, “Where to obtain service,” page 2).

Figure 5-1. Power board wiring connections

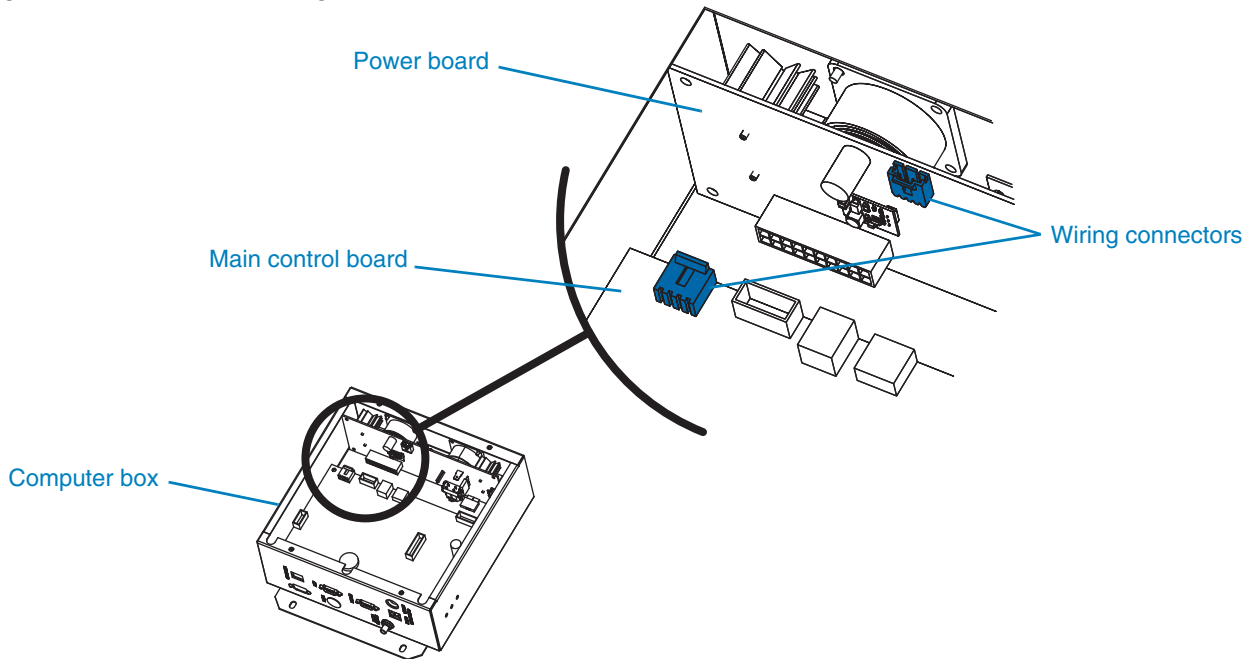

5.2.3

NTCIP alarm

An NTCIP alarm indicates an NTCIP communications error. This type of alarm is informational only and does not affect system performance. No troubleshooting is necessary.

5.2.4

AuxIO alarm

An AuxIO (auxiliary input/output) alarm indicates a communications error between the sign and one or more auxiliary devices. An auxiliary device might be a cellular modem installed at the sign, speed-detection radar connected to the sign's computer, or any other auxiliary equipment.

When an AuxIO alarm occurs:

1. Follow the safety requirements in Section 2, page 3.
2. Determine which device is malfunctioning.
3. Check the wiring connections between the device and the sign, ensuring they are proper and secure. Be sure to check the connections at both ends of the wiring.
4. If the connections are proper and secure, use the controller to determine whether the power circuits to the device are live.
5. If the power circuits are live, the device may be faulty and need to be replaced. Contact the factory (see Section 1.4, "Where to obtain service," page 2).

5.2.5

Voltage alarm

A voltage alarm results when the battery voltage is out of range.

The sign measures voltage and current from the battery and the solar charging circuit. You can use the controller to view the power values listed in Table 5-2.

Table 5-2. Power values

Code	Description
Vs	Sign voltage (battery), in volts
Is	Sign current (battery), in amperes
VI	Line voltage (solar charger), in volts
II	Line current (solar charger), in amperes

The out-of-range warning limit for Vs is configurable using the controller.

If a voltage alarm occurs:

1. Follow the safety requirements in Section 2, page 3.
2. Check battery voltage (see “Charging” on page 42).
3. If the voltage is low, charge the batteries. The alarm shuts off when battery voltage increases to 11.9Vdc, but the batteries should be charged to 12.65Vdc.
4. If the batteries do not need charging, check the battery cables and their connections to the batteries. Replace damaged cables and repair bad connections.
5. If the batteries are charged and the cables and cable connections are good, then the alarm may be a result of a power board failure. Contact the factory (see Section 1.4, “Where to obtain service,” page 2).

5.2.6

Temperature alarm

A temperature warning alarm results when either of these conditions occurs:

- One or more detected temperatures are out of range.
- The temperature inside the display cabinet is critically high.

The sign has several sensors that measure temperature. You can use the controller to view the temperatures listed in Table 5-3.

Table 5-3. Temperature values

Code	Description
Ts	Temperature inside sign display cabinet (ambient plus solar heat)
Tc	Temperature inside sign computer box
Ta	Temperature of ambient sensor

Out-of-range warning limits for Ts and Tc are configurable using the controller.

If a temperature alarm occurs, use the following information to troubleshoot the alarm.

High display-cabinet temperature

The temperature inside the display cabinet may be significantly higher than the ambient temperature, due to solar gain. If the temperature (T_s) is too high, the message sign display shuts down and the display is blank.

A temperature alarm can also occur if a temperature sensor, the sensor circuit board, or wiring to the sensor is faulty, even if the display cabinet temperature is not too high.

To troubleshoot high display-cabinet temperature:

1. Follow the safety requirements in Section 2, page 3.
2. Open the display cabinet door.
3. Locate the sensor circuit board, which is also the photocell board (see Figure 5-2).
4. Check wiring connectors to the sensor circuit board, ensuring they are proper and secure.
5. Check wiring and wiring connectors for damage, and repair or replace if necessary.
6. If wiring connections are secure and wiring is undamaged, the sensor circuit board may be loose or damaged. Inspect the sensor board and replace it if necessary (see Section 5.2.7).

High computer-box temperature

If the temperature inside the computer box (T_c) is high, the power board or a component on the board may have failed. In this case, the power board should be replaced. Contact the factory for a replacement power board (see Section 1.4, "Where to obtain service," page 2).

The power board replacement procedure should be performed by an authorized Wanco service technician.

5.2.7

Photocell alarm

A photocell alarm results when one or more photocell inputs are out of range. The message sign is equipped with two photocells, which are used for controlling the brightness of the display.

- If the display appears to be abnormally dim, one or both photocells may be blocked or defective.
- If the display appears to be abnormally bright, one or both photocells may have short-circuited or become damaged.

If a photocell alarm occurs:

1. Follow the safety requirements in Section 2, page 3.
2. Follow the procedures in Section 5.3, page 30, to access and inspect the main terminal strip inside the display cabinet.
3. Locate the photocells in the lower left corner of the display cabinet (see Figure 5-2).

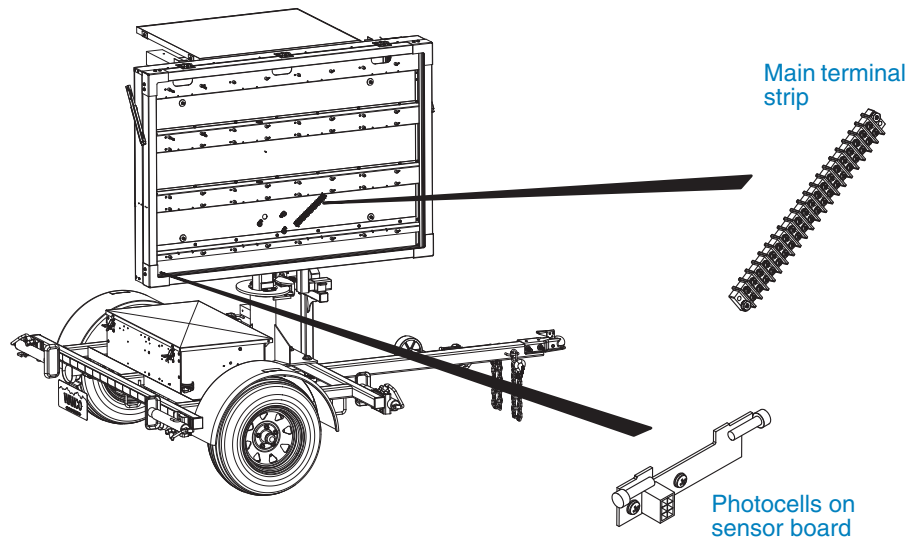
Figure 5-2. Photocells and main terminal strip

4. If either the front or rear photocell appears to be dirty or otherwise obstructed, clear it or use a soft, damp cloth to clean the photocell or photocell cover. For the front photocell, clean the display cabinet window if necessary (see Section 6.2.1, page 38).
5. Use the controller to view values for P1 and P2 (illumination detected by the photocells).
6. Choose one of the photocells and test it as follows:
 - a. While watching the controller screen, block all light from the photocell by holding a thick rag, work gloves, or any opaque object over it. Do not use your hands or a piece of paper to block the light.
 - b. With light blocked from reaching the photocell, the value shown for that photocell on the controller screen should be at or near zero (indicating no light and full dimming of the display).
 - c. While watching the controller screen, shine a flashlight at the photocell.
 - d. With light shining directly into the photocell, the value shown for that photocell on the controller screen should be at or near 100 (indicating bright light and full brightness of the display).
7. Repeat Step 6 for the other photocell.
8. If, when performing the previous steps, the values shown on the controller screen do not indicate full dimming and full brightness, then the photocell may be damaged or defective. To replace the photocells:
 - a. Use the controller to “blank” the message sign.
 - b. With the display cabinet door open, access the circuit board on which the photocells are mounted.

- c. A locking tab on the front of the photocell wiring connector keeps the connector attached to the circuit board. Remove the connector from the board by pushing the locking tab toward the connector, then pulling the plug sideways, away from the board.
 - d. Remove the screws that hold the circuit board in place, then remove the board and set it aside.
 - e. Insert the replacement photocell circuit board into place, attach it with the screws, and connect the photocell wiring by installing the wiring connector to the board.
9. Repeat Step 6 for the both photocells, then:
 - a. If the photocell values on the controller screen change as expected, the new photocells are correctly installed.
 - b. If the values do not change as expected, check the wiring connection at the photocell circuit board.
 - c. If all wiring connections are secure and the photocells do not appear to be working correctly, contact the factory (see Section 1.4, “Where to obtain service,” page 2).
 10. When done, secure the controller and then close and latch the battery box.

5.3 Main terminal strip

If wiring connections at the main terminal strip inside the display cabinet are loose or damaged, the message sign will not function properly. When instructed to access the main terminal strip by a qualified Wanco service technician or by a troubleshooting procedure, refer to Figure 5-2, page 29, and use the following steps:

1. Determine the location of the terminal strip inside the display cabinet by first locating the wiring conduit entry point on the back of the cabinet. The conduit runs from the computer box to the cabinet.
 - When facing the front of the display cabinet, the terminal strip is located immediately to the left of the conduit opening, behind one of the sign’s display modules.
 - You must remove the appropriate display module to access the terminal strip.
2. Based on the location of the conduit opening, determine which display module you need to remove.
3. Follow the procedures in Section 6.2.3, page 39, to remove the display module in front of the terminal strip.
4. Examine all wiring connections at the terminal strip. If any wiring connections are loose or damaged, repair if able or contact the factory for assistance (see Section 1.4, “Where to obtain service,” page 2).

5.4 Message display

Before troubleshooting display problems, use the controller to check for alarms. If you resolve the issue that caused an alarm, you may also resolve problems with the display.

To troubleshoot alarms, see Section 5.2, page 23. After troubleshooting alarms, use the following tables to troubleshoot the display.

- Table 5-4, “Troubleshooting a blank display”
- Table 5-5, “Troubleshooting messages that appear or disappear unexpectedly”
- Table 5-6, “Troubleshooting partial messages and duplicate characters,” on page 32
- Table 5-7, “Troubleshooting stuck LEDs,” on page 32
- Table 5-8, “Troubleshooting LED brightness problems,” on page 32

Table 5-4. Troubleshooting a blank display

Possible cause	Description	Solution
Program schedule	A programmed schedule may have “blanked” the display	Use the controller to determine whether a schedule is active or has recently ended; deactivate the schedule if appropriate
User control	A user may have directly or remotely “blanked” the display	Use the controller to put a message on the sign
Spaces in message	Displayed message may be all spaces	Use the controller to replace the current message
Bad cables or connections	Display cable connections may be loose, damaged, or corroded	Check cable connections at the computer box inside the battery box, and at the main terminals inside the display cabinet (see Section 5.3, page 30), to ensure they are proper and secure. Check cables for wear and damage. Replace cables if necessary.
Periodic self-test is running	Sign may be performing a periodic self-test	Message should reactivate automatically within a few minutes

Table 5-5. Troubleshooting messages that appear or disappear unexpectedly

Possible cause	Description	Solution
Control by auxiliary device	Message may be controlled by radar or other auxiliary device	Use the controller to access the auxiliary equipment configuration and turn off the device, then check whether the message sign behaves as expected
Program schedule	A programmed schedule may have “blanked” the display	Use the controller to determine whether a schedule is active or has recently ended; deactivate the schedule if appropriate
Remote-control by user	Message may be controlled by remote-control software	Determine whether a remote user is controlling the sign; if necessary, disconnect modem (located inside battery box)
Periodic self-test is running	Sign may be performing a periodic self-test	Message should reactivate automatically within a few minutes

Table 5-6. Troubleshooting partial messages and duplicate characters

Possible cause	Description	Solution
Bad cables or connections	Display module power or data cable connections may be loose or broken	Test and, if necessary, replace defective cables or display modules (see Section 5.2.1, page 24)
Faulty display modules	One or more display modules may be faulty	Test and, if necessary, replace defective display modules (see Section 5.2.1, page 24)

Table 5-7. Troubleshooting stuck LEDs

Possible cause	Description	Solution
Short circuit	LED or pixel driver may be shorted	Examine display module for damage, debris, moisture, or contact with metal on front or back of module (to remove module from display, see Section 5.2.1, page 24)
Defective LED or driver	LED or pixel driver may be faulty	Test display module by swapping it with a properly functioning module (see Section 5.2.1, page 24)

Table 5-8. Troubleshooting LED brightness problems

Possible cause	Description	Solution
Transparent window is dirty	The polycarbonate window that protects the display may be dirty	Clean the window (see Section 6.2.1, page 38)
Display position	Apparent brightness can be affected by the display position relative to traffic	Ensure the message sign is properly located and oriented (Section 4.4.1, page 16), and the trailer is level (see Section 4.4.2, page 17)
Brightness settings	Brightness settings control how bright the display appears	Use the controller to check brightness settings; change or restore defaults if necessary
Illumination control settings	Illumination settings control dimming of the display	Use the controller to check illumination control settings; change or restore defaults if necessary

5.5 Controller

If the controller does not operate and:

- The sign's power system appears to be off (e.g., the display is blank and the controller will not turn on), then the power system has shut down. For troubleshooting, see Section 5.6, page 33.
- The sign has power, see Table 5-9.

Table 5-9. Troubleshooting inoperable controller

Possible cause	Description	Solution
Ethernet cable	The controller receives its power and communicates with the message sign computer using an Ethernet cable	Check cable connections at the controller and computer box to ensure they are proper and secure; replace the cable if damaged
Automatic shutoff	After a period of inactivity, the controller shuts down automatically to save power	See the controller user-interface manual for on/off operation

5.6 Power failure

If the message sign display is blank and the controller will not turn on, the power system has shut down.

- If the power system was shut down intentionally (a common reason is when the sign is put into storage), the solution may be as simple as reinstalling a fuse in the battery box, reconnecting a battery cable, or exposing the solar panels to sunlight so they can charge the batteries. Before proceeding with troubleshooting, check the fuse and battery connections, then check the batteries to see whether they need to be charged (see “Charging” on page 42).
- If power was shut down automatically by the sign’s computer or low-voltage-disconnect circuit, see Table 5-10.
- Other power problems and solutions include those listed in Table 5-11.
- After solving the problem, allow the solar charging system to charge the batteries, or use the AC-powered charger to charge the batteries. Always charge batteries fully before using the message sign (see “Charging” on page 42).

Table 5-10. Troubleshooting automatic shutdown

Possible cause	Description	Solution
Solar panels covered	Solar panels may be partially or completely covered by dust or dirt, or snow	Clean the solar panels as instructed in Section 6.3.2, page 40
Solar panels obstructed	Solar panels may be obstructed by shadows	Clear obstruction or move the sign to avoid shadows from trees, buildings, and other tall objects
Solar panels damaged	Solar panels may be damaged from weather or vandalism, or altogether missing	Replace damaged or missing panels
Insufficient sunlight	Solar panels may be receiving insufficient sunlight due to weather or the season	Charge the batteries manually using the AC-powered charger (see “Charging” on page 42)
Faulty batteries	One or more batteries may be faulty or have reached their end of life	Test and charge batteries (see “Charging” on page 42); if one or more batteries will not hold a charge, replace them
Bad cables or connections	Solar power cables may be loose or damaged	Check cable connections to ensure they are proper and secure. Check cable for wear and damage. Replace cable if necessary.

Table 5-11. Troubleshooting power problems

Possible cause	Description	Solution
Dead batteries	One or more batteries may need recharging or replacing	Test and charge batteries (see “Charging” on page 42); replace any batteries that will not hold a charge
Bad cables or connections	Power, display, or battery cable may be loose, damaged, or corroded	Check cable connections to ensure they are proper and secure. Check cables for wear and damage. Replace cables if necessary.
Blown fuse	A fuse may have blown	Check fuses on the power board (see Figure 5-3) and replace if necessary
Faulty power board	Power board may be faulty	Contact the factory (see Section 1.4, page 2)

Figure 5-3. Fuses on the power board

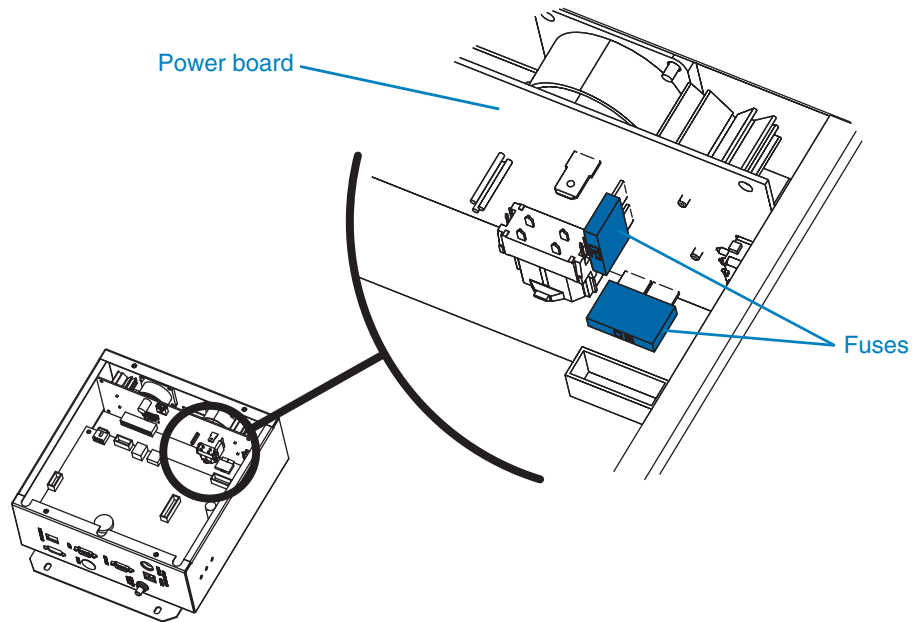

5.7

Radar

5.7.1

Before troubleshooting radar

Radar is powered by the message sign power system and controlled by the message sign computer.

- If the message sign power is off and all the status LEDs on the top of the computer box are off, see Section 5.6, page 33, for troubleshooting.
- If the message sign is operating properly and some status LEDs are on, but the radar LED is off and the radar is not functioning, see Section 5.7.2.

Radar is optional, auxiliary equipment that may not be included with your message sign (see Section 4.5.2, page 21).

5.7.2

Radar troubleshooting procedure

IMPORTANT!

After each step in the following procedure, check the radar status LED on the top of the computer box. When the LED is on or blinking, the radar is functioning properly.

To troubleshoot radar:

1. Use the controller to access the radar configuration screen. Verify the radar power is configured as "ON" and other radar settings are as expected.
2. Access the LED/switch board, which is attached to the underside of the computer box cover, and ensure the cable connections and wiring are proper, secure, and undamaged (see Figure 5-4). Repair or replace if necessary.

3. Check the radar power fuses and ground connection (see Figure 5-4). Replace the fuse if necessary.
4. Check wiring connections at the radar terminal strip inside the display cabinet (see Figure 5-5). Ensure they are proper, secure, and undamaged. Repair if necessary.
 - To access the radar terminal strip, remove the bottom left display module.
 - For instructions on removing a display module, see Section 6.2.3, page 39.
5. If all other steps failed to solve the problem, the radar head may have failed. Contact the factory (see Section 1.4, page 2).

Figure 5-4. Radar wiring connections and fuses

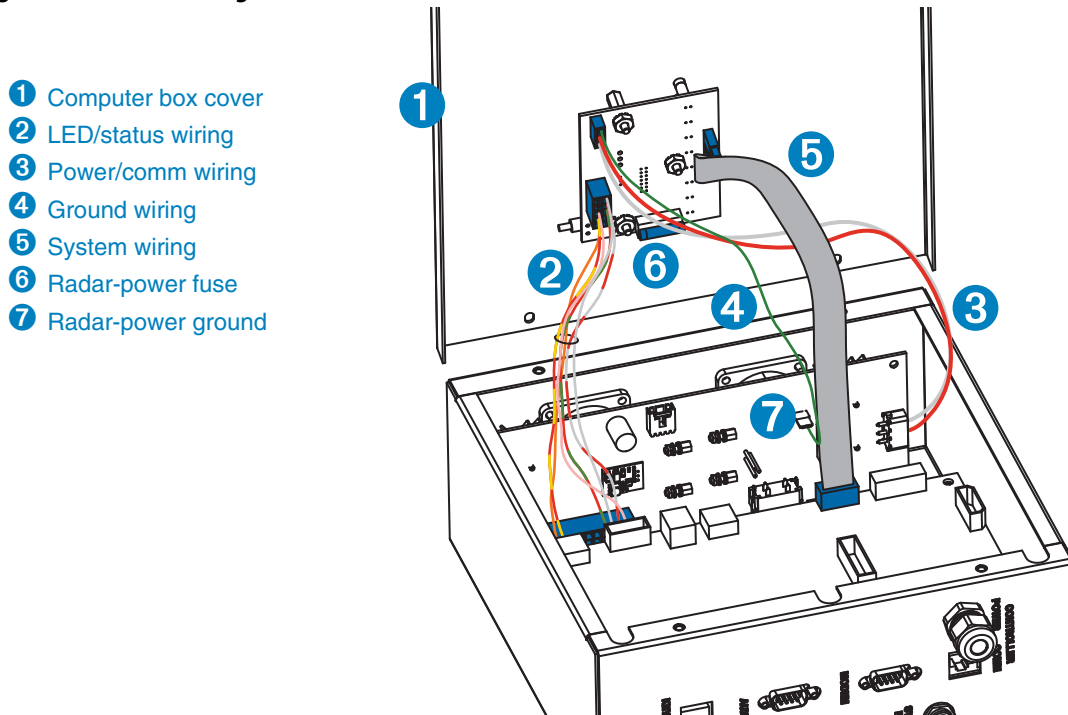
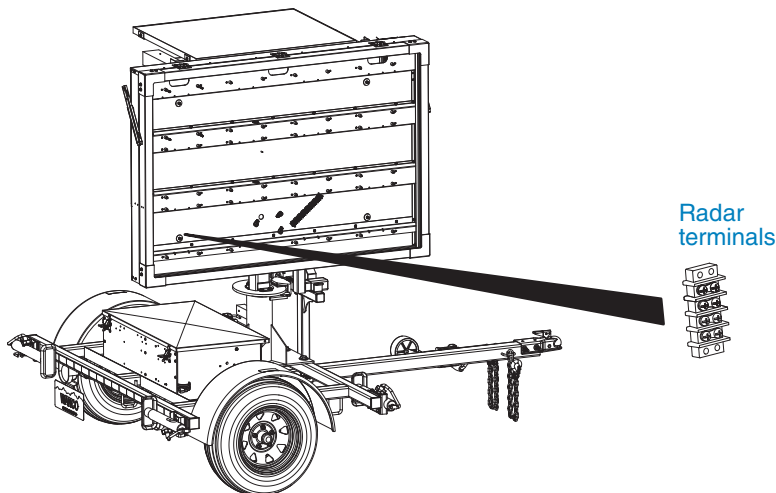

Figure 5-5. Radar wiring terminals



6 Maintenance

6.1 Periodic maintenance

When performing any maintenance on the system, follow the safety requirements in Section 2, page 3.

Repair or replace worn and damaged components immediately. Never use any equipment that is damaged or in need of repair.

CAUTION



During maintenance, adverse weather conditions can cause equipment damage and injury.

Whenever possible, perform maintenance indoors or in calm, dry weather.

CAUTION



Voltage surge could damage control circuits.

Before servicing electrical components, disconnect power cable from computer box.

Perform the following maintenance regularly:

- The message sign display comprises a matrix of display modules with sets of LEDs that light up to display messages on the sign.

WARNING



If the message sign is not working properly, a traffic accident could occur, resulting in serious injury or death.

Verify all display modules are functioning properly.

- Before using the sign, ALWAYS check the display modules for proper operation.
- Replacement modules are available from the factory (Section 1.4, "Where to obtain service," page 2).
- At least once a week, check the display cabinet window for cleanliness and cracks. Clean or replace window when necessary.
- All components in the battery box will operate more efficiently and have a longer lifespan if they are free of dirt and dust. Keep the interior of the battery box and components inside the battery box clean. Observe battery safety requirements when working on or around batteries (see "Safety" on page 41).

6.2 Display cabinet

The display cabinet protects the LED display modules and other electronics inside the cabinet. The display-cabinet door is hinged at the top and latched on the sides and bottom. The door props open for servicing.

- The door frame holds a clear, polycarbonate-resin thermoplastic window. During use, the window will become dirty and require cleaning (see Section 6.2.1).
- The gasket between the door frame and the display cabinet can become worn over time. The gasket is important for sealing the cabinet against the weather, and should be replaced if worn or damaged.
- Ensure the cabinet door is closed and latched when the message sign is not being serviced.

6.2.1 Polycarbonate window

To clean the window:

1. Follow the safety requirements in Section 2, page 3.
2. Open the display cabinet door.
3. Follow these guidelines:
 - Use a cleaning solution of mild soap and warm water. If necessary, commercial cleaning solutions, such as Formula 409®, are acceptable. Do not use chemical or industrial cleaning solutions.
 - Use a sponge or soft cloth and clean the window gently, using care not to scratch the surface. Do not use a brush or squeegee.
 - To prevent spotting or streaking, dry the surface with a soft cloth or moist sponge.
4. When done, close and latch the display cabinet door.

6.2.2 Photocells

To clean the photocells:

1. Follow the safety requirements in Section 2, page 3.
2. Locate and inspect the photocells (see Figure 5-2, page 29).
3. If either the front or rear photocell appears to be dirty or otherwise obstructed, clear or clean it using a soft, damp cloth on the photocell or its cover. For the front photocell, clean the window if necessary (see Section 6.2.1).
4. When done, close and latch the display cabinet door.

6.2.3

Display modules

The display modules can be replaced when damaged or if LEDs fail to light.

Each module has an address, which marks its designated location in the display. All modules are interchangeable, and their addresses are assigned by initialization. Therefore, after replacing modules in the cabinet, initialization is required to ensure messages are displayed correctly.

IMPORTANT!

You must have advanced- or service-level access to the controller in order to initialize a replacement display module.

To replace a display module:

1. Follow the safety requirements in Section 2, page 3.
2. Identify the display module to be replaced, and remember its location.
3. Use the controller to “blank” the message sign.
4. Open the display cabinet door (which is hinged at the top and latched on the sides and the bottom).
5. Remove the display module:
 - a. Identify the module and locate the four retaining nuts that hold it in place.
 - b. Using the supplied nut wrench or a 5/16-inch nut driver, remove the four nuts.
 - c. Carefully pull the display module away from the cabinet to expose the wiring connections on back of the module. The wiring can be damaged if you use too much force.
 - d. Being careful to avoid using too much force, first unplug the power connector on back of the malfunctioning display module by pulling the connector straight out, away from the module, then unplugging the data input wires by pushing the locking tab down and pulling the plug sideways, away from the connector. Repeat for the data output wires. (The lower-right module does not have output wiring.)
 - e. Set the module aside.
6. Install and initialize the new module:
 - a. Reverse the procedure to install the replacement module in place of the one you removed.
 - b. Use the controller to access the display module diagnostics, then initiate the message sign and start a new self-test.
 - c. After initialization is complete, use the controller to put a test message on the sign, and ensure the sign is working as expected.
7. When done, close and latch the display cabinet door.

6.3 Power system

6.3.1 Overview

The message sign is powered by 12-volt batteries. Solar panels are used for charging the batteries.

The charging system runs continuously, keeping the batteries charged. The system automatically detects when the batteries are fully charged and will not overcharge them.

Under optimal conditions, the batteries will remain charged and the message sign can be used without having to charge the batteries using an external charger. If you use the message sign continuously and the solar panels are not exposed to full sunlight all day, the solar charging system may not keep the batteries charged sufficiently.

If there is not enough sunlight to keep the batteries fully charged, you will need to charge the batteries using the external AC-powered charger, which is located inside the battery box (see “Charging” on page 42).

The low-voltage-disconnect circuit detects when the battery charge falls below 11.2 volts DC, and shuts down power to the message sign. If a shutdown occurs, the message sign will not function; the batteries must be fully charged.

6.3.2 Solar panels

For the solar charging system to function properly, the solar panels must be exposed to full sunlight during daylight hours. If the location where the message sign will be used is not a sunny location, the batteries must be charged using the external AC-powered charger, which is located inside the battery box (see “Charging” on page 42).

The solar panels must be kept clean and completely unobstructed:

- When necessary, clean the solar panels with a soft cloth or sponge and a cleaning solution of mild detergent and warm water.
- If a shadow or any obstruction blocks even a portion of any of the solar panels, charging will be negatively affected and a significantly longer charge time will be necessary.

6.3.3 Batteries

Although the message sign batteries are sealed and maintenance-free, regular care will ensure proper function and extend battery life.

- When working on or around the batteries, always observe battery safety precautions (see “Safety” on page 41).
- Routinely inspect batteries and cables, clean surfaces and terminals, and check battery charge.

See the following pages for battery safety and care instructions.

Safety



⚠ DANGER

Explosive gases can cause blindness and severe injury.

When working on or near batteries:

- Wear eye protection
- Prevent sparks and open flames
- No smoking anywhere in the vicinity
- Keep children clear of the area



⚠ DANGER

Sulfuric acid can cause blindness and severe burns.

- Use caution when working on or near batteries
- Avoid contact with skin, face, and eyes
- Upon contact, seek medical help immediately
- Keep out of reach of children



CAUTION

Voltage surge could damage control circuits.

Before working with batteries, disconnect power cable from computer box.

- Even when the batteries are not in operation, self-discharge generates hydrogen gas that can explode. Always store and work on batteries in a well ventilated area.
- Always wear proper eye, face, and hand protection when working on or near batteries.
- Keep all sparks, flames, and cigarettes away from batteries at all times.
- Never lean over batteries when testing or charging.
- To prevent short circuits and sparks, exercise caution when working with metallic tools or conductors near batteries.
- To reduce the risk of sparks, ensure connectors make good contact with battery terminals.
- Replace cables that you suspect might be worn or damaged. Replace cables that have visible fraying, cracks, or bare wires.
- Always disconnect power cable from computer box before disconnecting battery cables. The computer box is located inside the battery box.
- If disconnecting message sign battery cables, always disconnect positive (+) cable first.* Do not allow positive power cable to short to ground.
- At least once every three months, coat cable connections with a protective spray, non-metallic grease, or petroleum jelly (such as Vaseline® brand) to prevent corrosion. Keep battery hold-downs painted.

**Removing the positive cable first is a requirement for negative-ground systems.*

- To lengthen battery life and prevent freezing, always keep batteries fully charged and keep cable connections clean and tight.
- Visually inspect batteries for physical damage, including cracks and leaking. Always replace damaged batteries immediately. Dispose of old batteries in accordance with local regulatory codes.
- Keep the battery box lid closed and latched unless you are performing maintenance, charging the batteries, or using the touchscreen controller.

Charging

Battery voltage should be checked once a week, to ensure the charging system is keeping the batteries charged. In northern locales during winter, when sunlight is less intense, battery voltage should be checked more often. For an overview of the charging system, see Section 6.3.1, page 40.

If the battery voltage is low because the charging system is not able to fully charge the batteries, use the external AC-powered charger when the batteries need charging (see “External AC-powered charger” on page 44).

To determine charge requirements, perform a voltage test as described below.

Voltage testing

Perform an open-circuit voltage test with a DC voltmeter or multimeter. Because the message sign’s maintenance-free batteries are sealed, an open-circuit voltage test is the only method for determining the state of charge.

1. Observe battery safety precautions (see “Safety” on page 41).
2. Turn off all electrical loads and halt battery charging from both the solar panels and AC charger.
3. Ensure battery cables are disconnected and terminals are clean.
4. For accurate voltage readings, wait at least one hour to allow the battery voltage to stabilize.
5. Using a DC voltmeter or multimeter, measure and record the DC voltage across the positive and negative terminals of each battery.
6. If the voltage varies between batteries, recharge the batteries and perform the test again, or obtain appropriate test equipment from the battery manufacturer and follow the manufacturer’s instructions.
7. Correct the voltage readings to 80°F (27°C). Using ambient air temperature:
 - Add 28 mV (0.028 volts) per cell for every 10°F above 80°F (5.6°C above 27°C)
 - Subtract 28 mV (0.028 volts) per cell for every 10°F below 80°F (5.6°C below 27°C).
 - Each 12-volt battery has two 6-volt cells.
8. Refer to Table 6-1 to determine the battery charge requirements based on the corrected voltage.

Table 6-1. Battery charge requirements

Charge level,%	Open-circuit voltage, volts		Approx. required charge time, hrs.		
	6V batt.	12V batt.	5A	10A	20A
100	6.37	12.73	0	0	0
95	6.34	12.68	3	1	1
90	6.31	12.62	5	2	1
85	6.28	12.56	8	4	2
80	6.25	12.50	10	5	3
75	6.22	12.44	13	6	3
70	6.19	12.37	16	8	4
65	6.16	12.31	18	9	4
60	6.12	12.24	21	10	5
55	6.09	12.17	23	12	6
50	6.05	12.10	26	13	6
45	6.37	12.03	28	14	7
40	6.34	11.96	31	16	8
35	5.95	11.89	34	17	8
30	5.91	11.81	36	18	9
25	5.87	11.74	39	19	10
20	5.83	11.66	41	21	10
15	5.79	11.59	44	22	11
10	5.75	11.51	47	23	12
5	—	—	—	—	—
0	—	—	—	—	—

Notes

1. Determine the battery charge level from the voltage test readings.
2. If charge level is above 70%, no charging is required. If charge level is below 10%, the battery may need replacing. Otherwise, determine the approximate required charge time from the table.

External AC-powered charger

To charge the batteries with the external AC-powered charger, located inside the battery box:

1. Observe battery safety precautions (see “Safety” on page 41).
2. Observe the following charging requirements:
 - Avoid charging batteries at temperatures above 120°F (49°C).
 - Never charge a frozen battery. Thaw batteries completely before charging.
 - Always charge batteries fully. Undercharging causes stratification and may result in the message sign shutting down unexpectedly.
3. Connect the charger to a standard 120-volt or 240-volt commercial power outlet.
 - If the charger appears not to be working, the fuse on the charger may be blown, or the power outlet may not be switched on.
 - The charger will not overcharge the batteries, even if left unattended for an extended period.
4. Charge the batteries until they reach 12.65 volts DC.
5. After charging is complete, disconnect the charger from the power outlet and stow the power cord inside the battery box.
6. Use the controller to program the message sign if necessary.
7. Close and latch the battery box.

Cleaning

- Observe battery safety precautions (see “Safety” on page 41).
- Keep batteries clean to avoid accumulation of dust, dirt, and grime.
- To clean batteries, use a solution of 50% baking soda and 50% water. After cleaning, rinse batteries with clean water and allow to dry thoroughly.
- Clean battery terminals, particularly if they are warm, hot, or corroded. Scour the terminals and the inside of the cable clamps using a battery post or clamp cleaner, or a wire brush, until they have a bright metallic shine.
- At least once a year, visually inspect terminals and cables for signs of corrosion, especially in hot temperatures.

Replacing

To replace a battery, follow these steps:

1. Observe battery safety precautions (see “Safety” on page 41).
2. Disconnect power cable from computer box.
3. Disconnect the positive (+) cable from the battery.*
4. Disconnect the negative (-) cable from the battery.
5. Remove the hold-down brackets that keep the battery in place.
6. Taking care to prevent injury, lift the battery out of the battery box. A battery is heavy, and you may need assistance to lift it.
7. Inspect the bottom of the battery box for corrosion and other damage. Clean the bottom of the battery box and any other components in the battery box that need cleaning.
8. Inspect the battery cables for corrosion and damage. Clean or replace the cables as necessary for ensuring a good connection.
9. Install the new battery and secure it with the hold-down brackets. Replace the old battery with a new battery of the same type.
10. Reconnect wiring (see Figure 6-4, page 52), taking care not to over-tighten the cable clamps:
 - a. Connect the negative (-) cable to the replacement battery.
 - b. Connect the positive (+) cable to the replacement battery.
11. Reconnect power cable to computer box.

Storing

- Observe battery safety precautions (see “Safety” on page 41).
- Before storing the message sign or batteries:
 - See Section 6.6, “Storing the message sign,” page 47.
 - Clean the batteries as described in “Cleaning” on page 44.
 - To prevent freezing, ensure all batteries are fully charged (see “Charging” on page 42).
- Store batteries in a cool, dry, well-ventilated location. The storage temperature should remain as low as possible without dropping below 32°F (0°C), and should not exceed 80°F (27°C).
- Store batteries safely out of reach of children and pets.
- Check state of charge every week.
- Charge stored batteries every 30 days.

**Removing the positive cable first is a requirement for negative-ground systems.*

6.4 System reset

The system reset button is sometimes used during troubleshooting and maintenance procedures. Pressing it causes the message sign computer to shut down and restart. DO NOT press the system reset button unless instructed to do so by a qualified Wanco service technician or by a troubleshooting or maintenance procedure.

IMPORTANT!

If the message sign battery charge is below 12.10 volts, DO NOT press the system reset button.

When the battery charge is low and you press the system reset button, the message sign computer will shut down and will not restart until the batteries are fully charged.

ALWAYS check the battery charge before pressing the system reset button.

6.5 Software update

It may sometimes be necessary to update the software on your message sign's computer. This should only be done when recommended by a Wanco service technician. The update procedure takes 20 to 30 minutes to complete.

To update the message sign software:

1. Obtain the software update as instructed by the Wanco service agent, and save it to an empty USB flash drive.
2. Configure the sign to show a message. Choose any message. This is so you can see when the sign restarts later in the procedure.
3. Initiate a system reset:
 - a. See important information in Section 6.4.
 - b. Check the batteries and charge them if necessary.
 - c. Press the System Reset button on the computer box (Figure 6-1), which is located inside the battery box. DO NOT press the button without first checking the batteries.
4. After the sign restarts and the message you chose appears on the display, insert the flash drive into the USB port on the computer box (Figure 6-1). This initiates the software update.
5. It can take up to 20 minutes for the computer to run the update process. When the update is complete, the system reboots and the sign returns to normal operation.
6. After the sign restarts and the message you chose appears on the display, the controller will update its software automatically. If the controller does not respond when you activate it, wait 10 minutes for it to complete its update process.
7. After the update is complete, you can confirm the update by using the controller to access the message sign ID information. (For instructions, see the controller user-interface manual.)

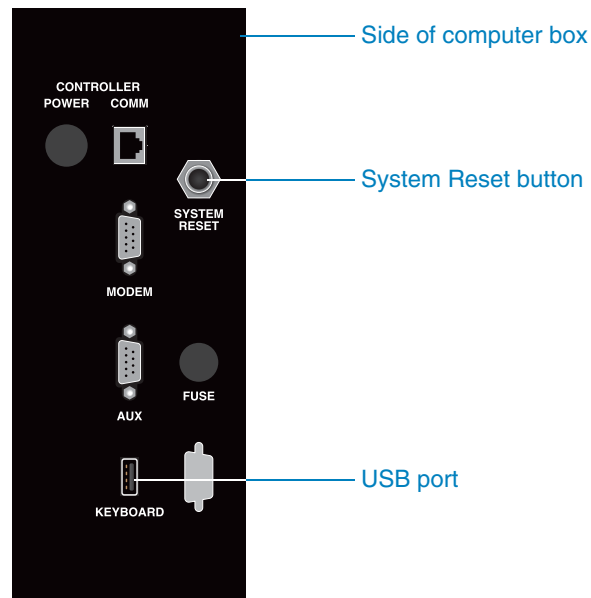
Figure 6-1. Reset button and USB port on computer box

6.6

Storing the message sign

Before storing the message sign, take the following steps to prevent damage to electrical components:

1. Observe battery safety precautions (see “Safety” on page 41).
2. Disconnect power cable from computer box, which is located inside the battery box.
3. Disconnect message sign cable from computer box.
4. If storing for more than a month without active solar charging, disconnect the cable from the negative (-) battery terminal.

CAUTION



Voltage surge could damage control circuits.

Before disconnecting battery cable, ensure power cable is disconnected from computer box.

6.7 Winch cable replacement

It may sometimes be necessary to replace the winch cable. Under normal use, the cable will last the life of the message sign. If the cable is damaged, it must be replaced.

The cable replacement procedure requires removing the old cable and running a new one through the tower, connecting it to the cable pin at the bottom and the winch at the top. Instructions are provided with the cable replacement kit.

If the winch cable broke due to stress of having the mast hitch pin engaged while operating the winch, then it is likely the cable pin is also damaged. Using a flashlight, inspect the cable pin, which is located at the bottom of the mast under the trailer. If the pin is bent or in poor condition, it must be replaced.

To order a cable replacement kit, contact the Wanco Service Department (see Section 1.4, "Where to obtain service," page 2).

6.8 Wiring

For wiring, see the following diagrams.

- Figure 6-2, "Trailer wiring," on page 49
- Figure 6-3, "Display cabinet wiring," on page 50
- Figure 6-4, "Battery box wiring," on page 52

6.9 Replacement parts

For replacement parts, see the following diagrams and parts lists, or contact the Wanco Service Department (see Section 1.4, "Where to obtain service," page 2).

- Figure 6-5, "Replacement parts: trailer assembly," on page 53
- Figure 6-6, "Replacement parts: tower assembly," on page 54
- Figure 6-7, "Replacement parts: display cabinet assembly," on page 55
- Figure 6-8, "Replacement parts: drawbar assembly," on page 56
- Figure 6-9, "Replacement parts: battery box assembly," on page 57

Figure 6-2. Trailer wiring

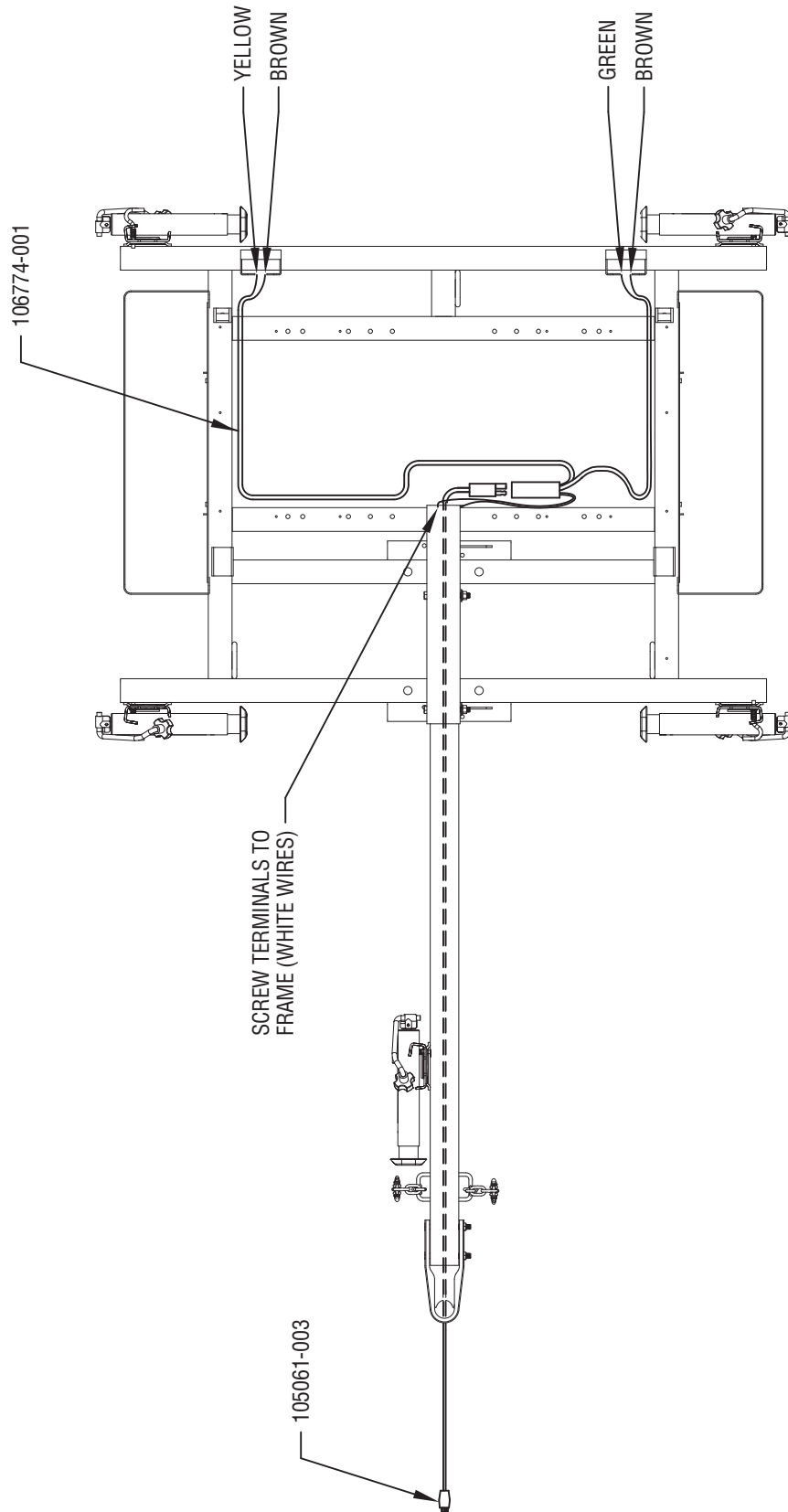
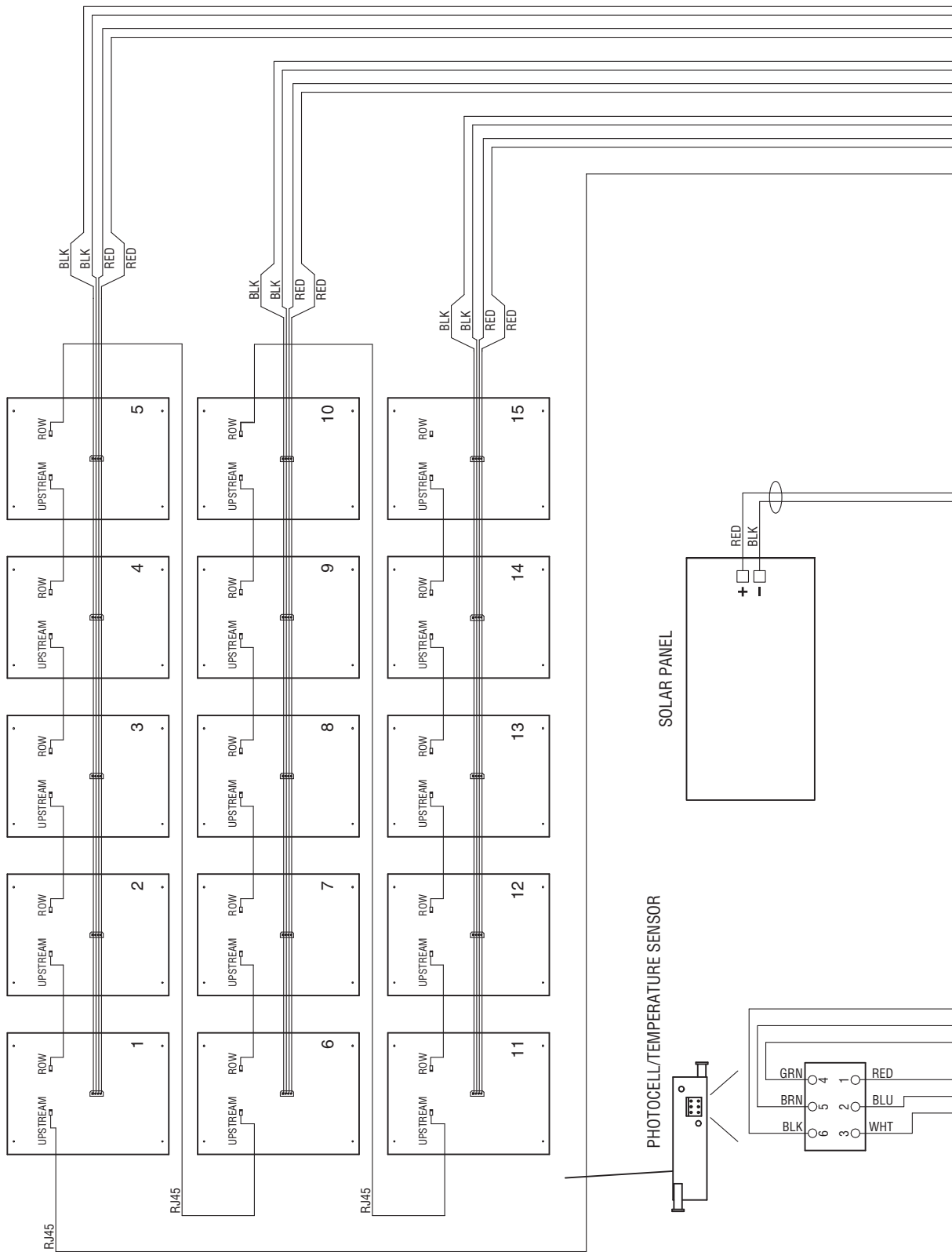
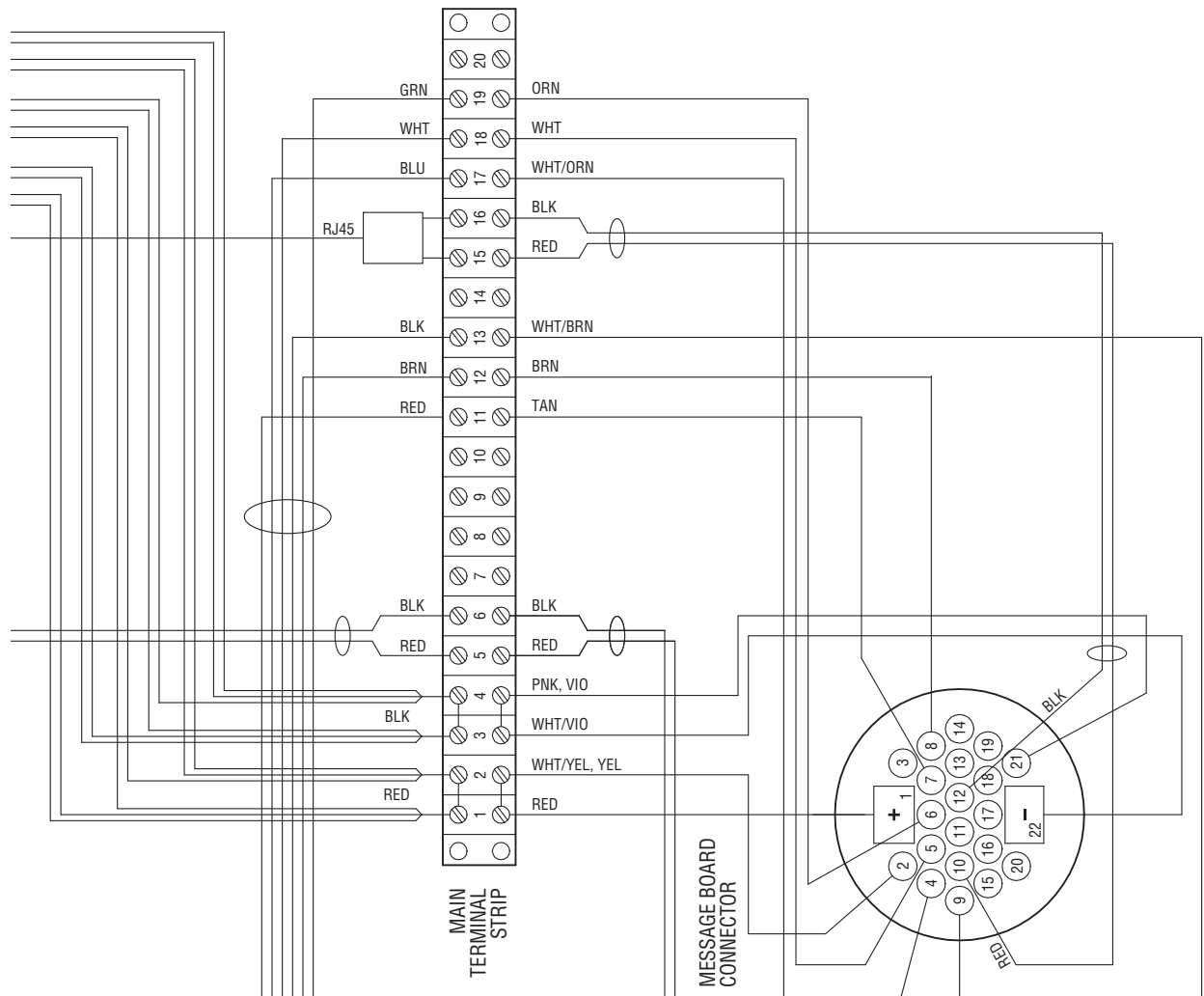

Figure 6-3. Display cabinet wiring





BATTERY & SOLAR PANEL INPUT CONNECTOR PIN OUT

PIN	COLOR	PURPOSE	GA	TERM BLK #
7	RED	SOLAR POWER +	12	5
15	BLK	SOLAR POWER -	12	6

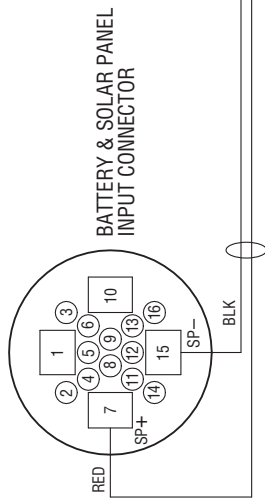

MESSAGE BOARD CONNECTOR PIN OUT

PIN	COLOR	PURPOSE	GA	TERM BLK #
1	RED	BATTERY +	14	1
2	WHT/YEL, YEL	BATTERY +	18, 18	2
3	NOT USED			
4	ORN	PHOTOCELL 2	18	19
5	WHT	PHOTOCELL 1	18	18
6	WHT/ORN	PHOTOCELL POWER	18	17
7	TAN	TEMP SENSOR POWER	18	11
8	BRN	TEMP SENSOR INPUT	18	12
9	WHT/BRN	TEMP SENSOR GROUND	18	13
10	RED	DATA CABLE RED	22	15
11	NOT USED			
12	BLK	DATA CABLE BLACK	22	16
13	NOT USED			
14	NOT USED			
15	NOT USED			
16	NOT USED			
17	NOT USED			
18	NOT USED			
19	NOT USED			
20	NOT USED			
21	PNK, VIO	BATTERY -	18, 18	4
22	WHT/ VIO	BATTERY -	14	3

Figure 6-4. Battery box wiring

WARNING

Fire hazard.
When working with batteries, never allow positive wiring to short to ground.

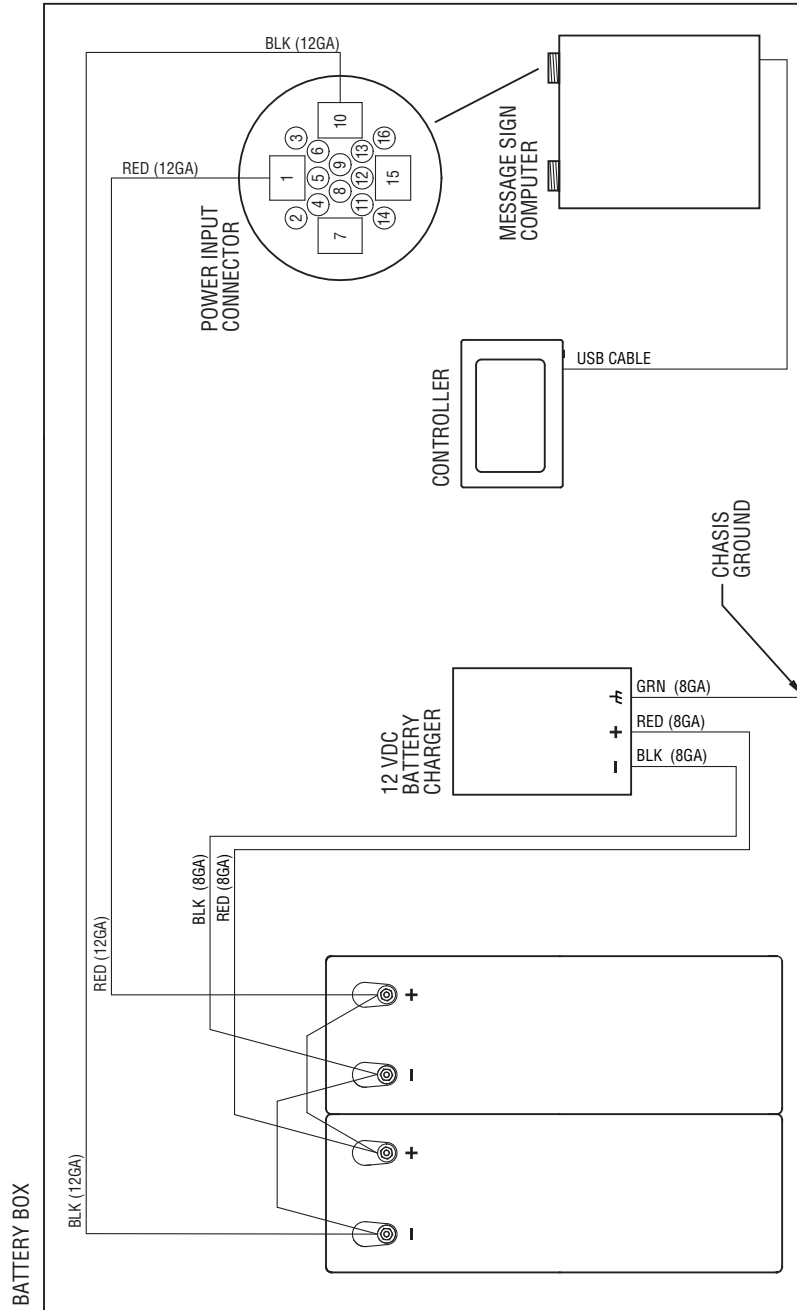
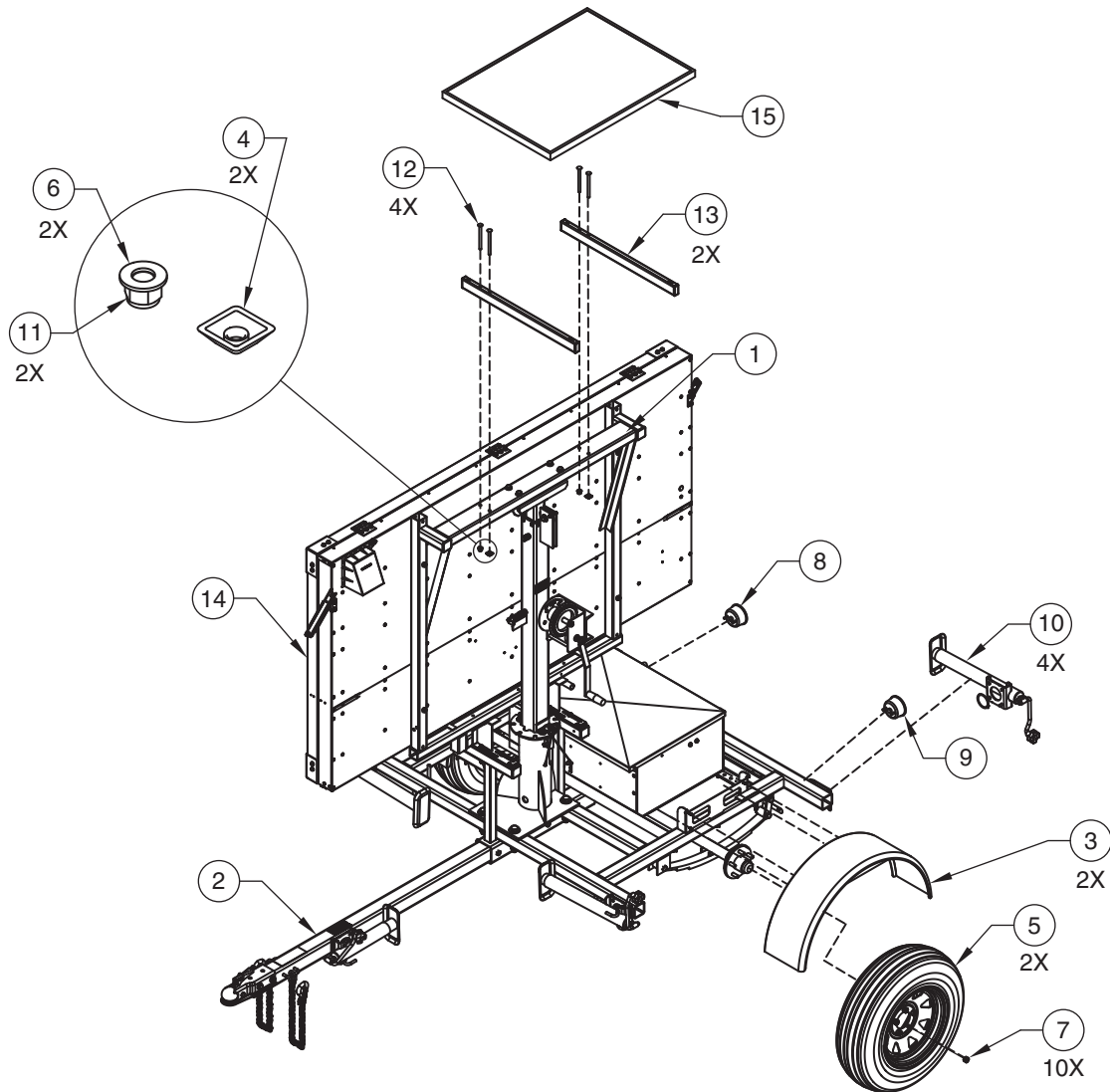
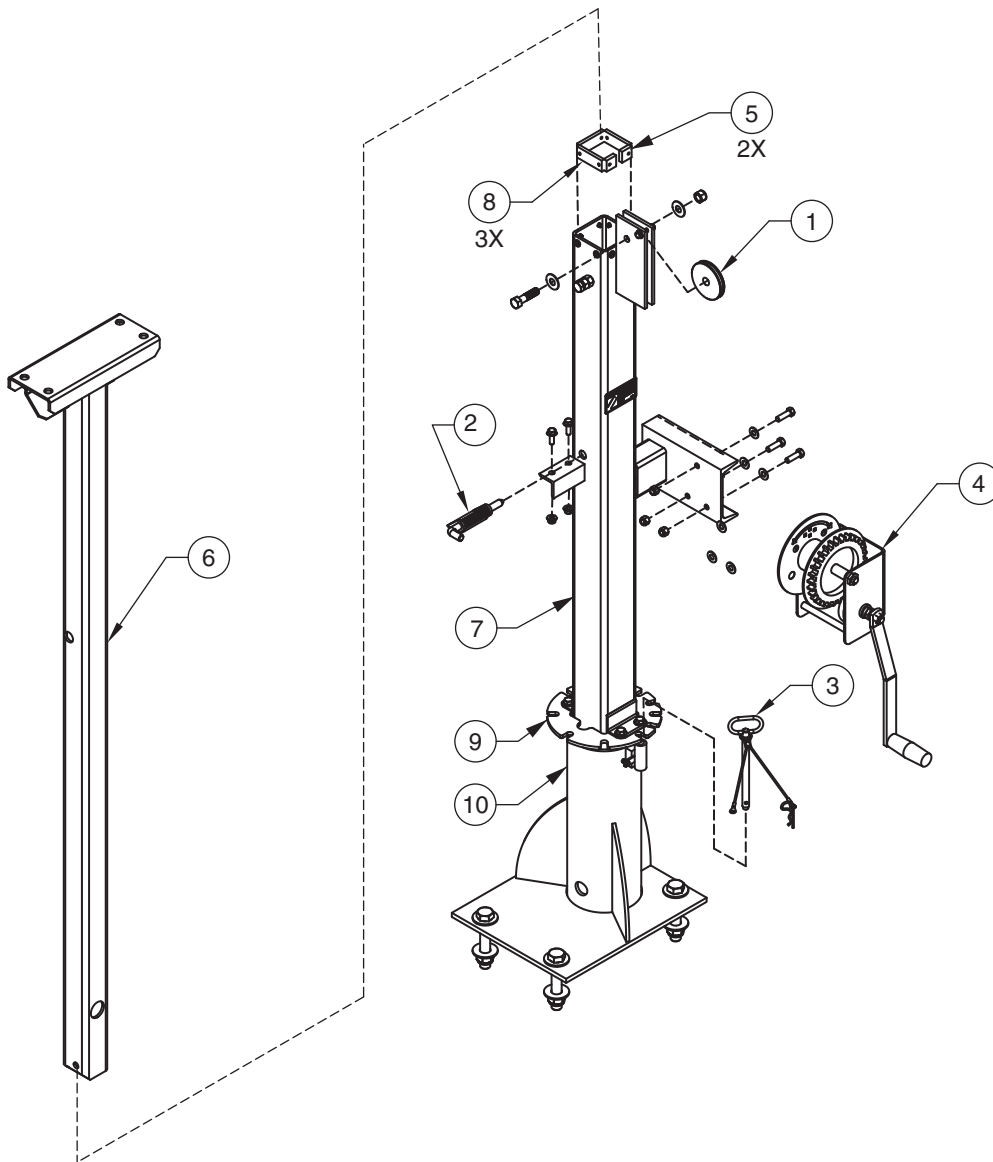



Figure 6-5. Replacement parts: trailer assembly



Item No.	Part No.	Description	Qty.
1	213708-P2	FR,CAB,WTSP,VTWR,W/BAT BX,BLK	1
2	108797-000C1	DWBR,TRLR,CMN SM,DOM,2"BALL,PDR	1
3	108420-200P1	FNDR,RND,CMN,SM TRLR,BOLT ON,ORN	2
4	105653-001	NUT-SCTY,SLOPED,.375(3/8)-16,ZP	2
5	104591-001	TIRE/WHL ASSY,4.80-12BB,DIAMOND SPK	2
6	104178-001	WSHR-.406(3/8)x.875x.045,SS	2
7	101323-001	LUG NUT	10
8	100259-001	TAIL LT-STOP,TURN&TAIL,NO LICENSE	1
9	100258-001	TAIL LT-STOP,TURN&TAIL,LICENSE	1
10	100143-001	JACK,SWVL,TM,2K,TW,13"TRVL,W/BASE	4
11	100073-001	NUT-HEX,NYLinsr,.375(3/8)-16,ZP,COU	2
12	214249	SCR-CRG,.375(3/8)-16x4.000,G5,ZPS	4
13	213706	TUBE,MNT,WCMN,SLPNL,VTWR,LONG	1
14	213703	SGN ASSY,MSG,VTMM,FLT,LG,AMBR	1
15	202485	SOL PNL SUBASSY-85W,WIRED	1

Figure 6-6. Replacement parts: tower assembly



Item No.	Part No.	Description	Qty.
1	100166-001	PULLEY-SINGLE GROOVE,STL,3"OD	1
2	100394-001	LTCH,HNG,1/2" SPR PIN,LH,ZINC CHRМ	1
3	100495-001	PIN-HITCH,.500x6.50,w/COT	1
4	101007-002	WINCH-H.CRANK,1500 LB CAP'Y,NO HN	1
5	10615-001F	GUIDE BLOCK-1"X1"X 5/16"THK,NYLON	2
6	206676-P1	WLDMNT,MAST SECT,WTMVMS,MB,ТОP	1
7	206677-P1	WLDMT,MAST SECT,WVTMM-L/M,BTTM	1
8	206873-F	GBLK,RECT,2.6X1.0X.27,NYL	3
9	213219-Z1	PLATE,LK,WTSP,VERT TWR	1
10	213872-P1	WLDMT,SWVLB,WTSP,VTWR,W/PIN LK	1

Figure 6-7. Replacement parts: display cabinet assembly

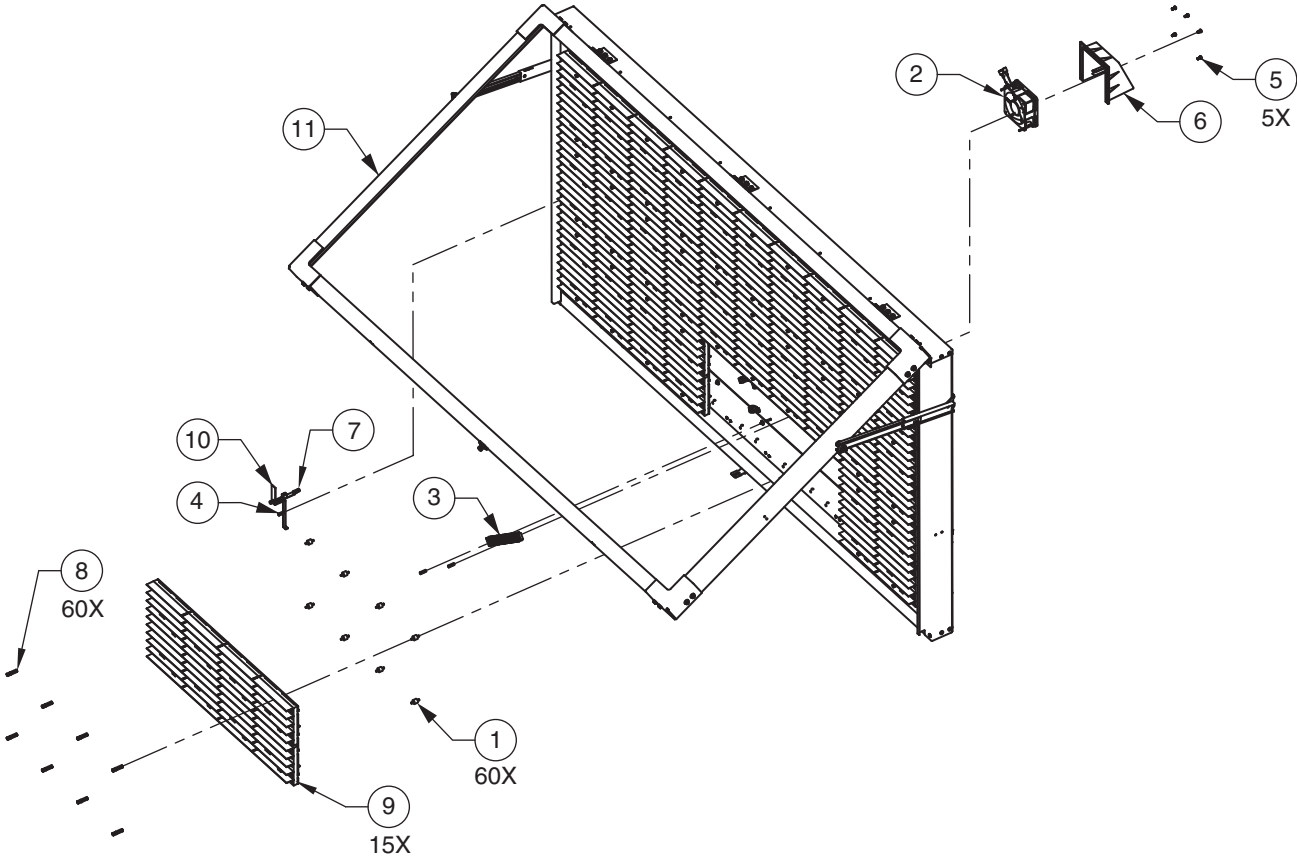

Item No.	Part No.	Description	Qty.
1	102314-001	VIB MOUNT,CR45,8-32 M/M	60
2	102873-001	FAN,BBRG,120X120X38MM,109CFM,12VDC	1
3	103097-001	TERM BLOCK-.438 PITCH,#6 SCR,20X	1
4	106051-001	STDF-HX,F/F,# 8-32x.875,AL,BLK	3
5	106343-001	SCR-PAN,832UNC X .50L,CONE SEMS	4
6	106543-001	FAN HOLDER/COVER,MB CABINET	1
7	106850-001	PCB ASSY MINI PHOTOCEL	1
8	107557-001	NUT,#8-32,EXT AL,MB	60
9	204071	CHARACTER ASSY-9" LED BOARD EU-MINI	15
10	208223-P2	BRKT,MNT,WVTM,MAT CAB,PHCL	1
11	213697	WDW,DOOR,WTMM,FLT CAB,LG	1

Figure 6-8. Replacement parts: drawbar assembly

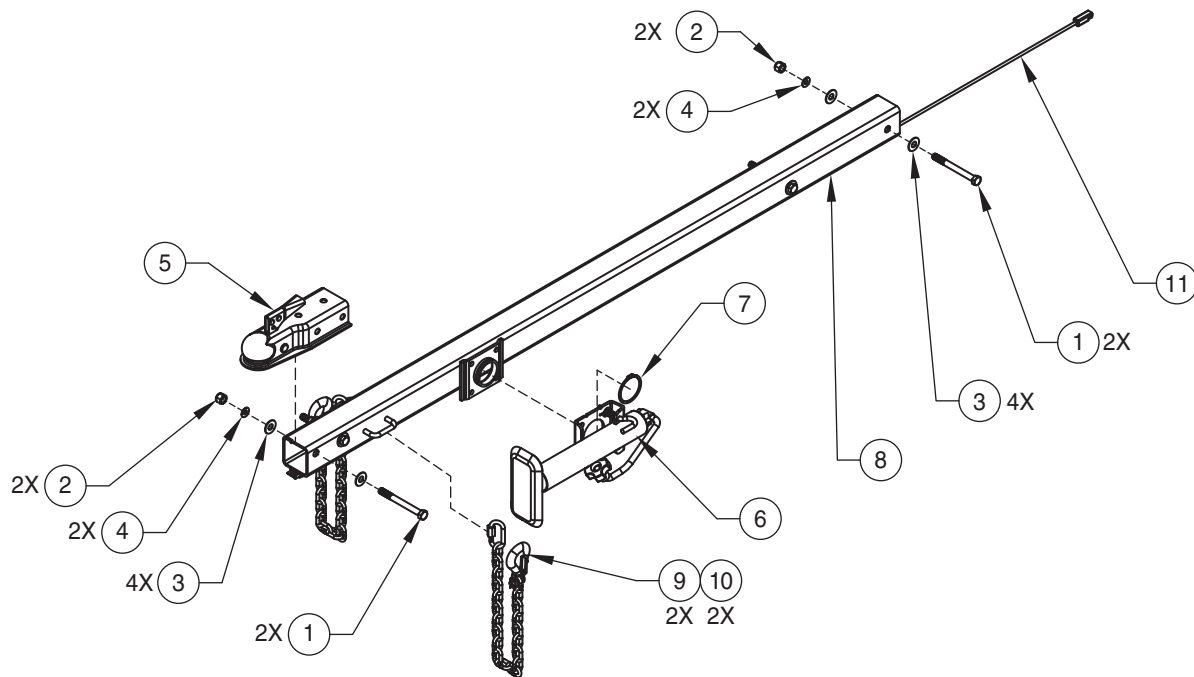

Item No.	Part No.	Description	Qty.
1	100216-017	SCR-HEX,.500(1/2)-13x5.000,G5,ZPS	4
2	100652-001	NUT-HEX,.500(1/2-13),ZP	4
3	106006-001	WSHR-FLAT,M14,S.S.	8
4	100713-001	LKWSHR-SPLIT,.512(1/2)X.869X.125,ZP	4
5	101677-002	HITCH-BALL,2"DIA,FITS 3"DRAWBAR	1
6	100943-001	JACK,SWVL,TM,2K,TW,10"TRVL,W/BASE	1
7	102919-003	RING-SNAP,FULTON SWIVEL JACKS,2.50"	1
8	103409-001P1	DWBR,TRLR,CMN SM,DOM,2"BALL,ORN	1
9	104859-001	CHAIN ASSY,1/4" W/HOOK-CLEVIS SLIP	2
10	201432	LINK-QUICK,5/16"X2 7/8"LONG,1540 LB	2
11	105061-003	HARNES-TAILLIGHT,MAIN,128" LONG	1

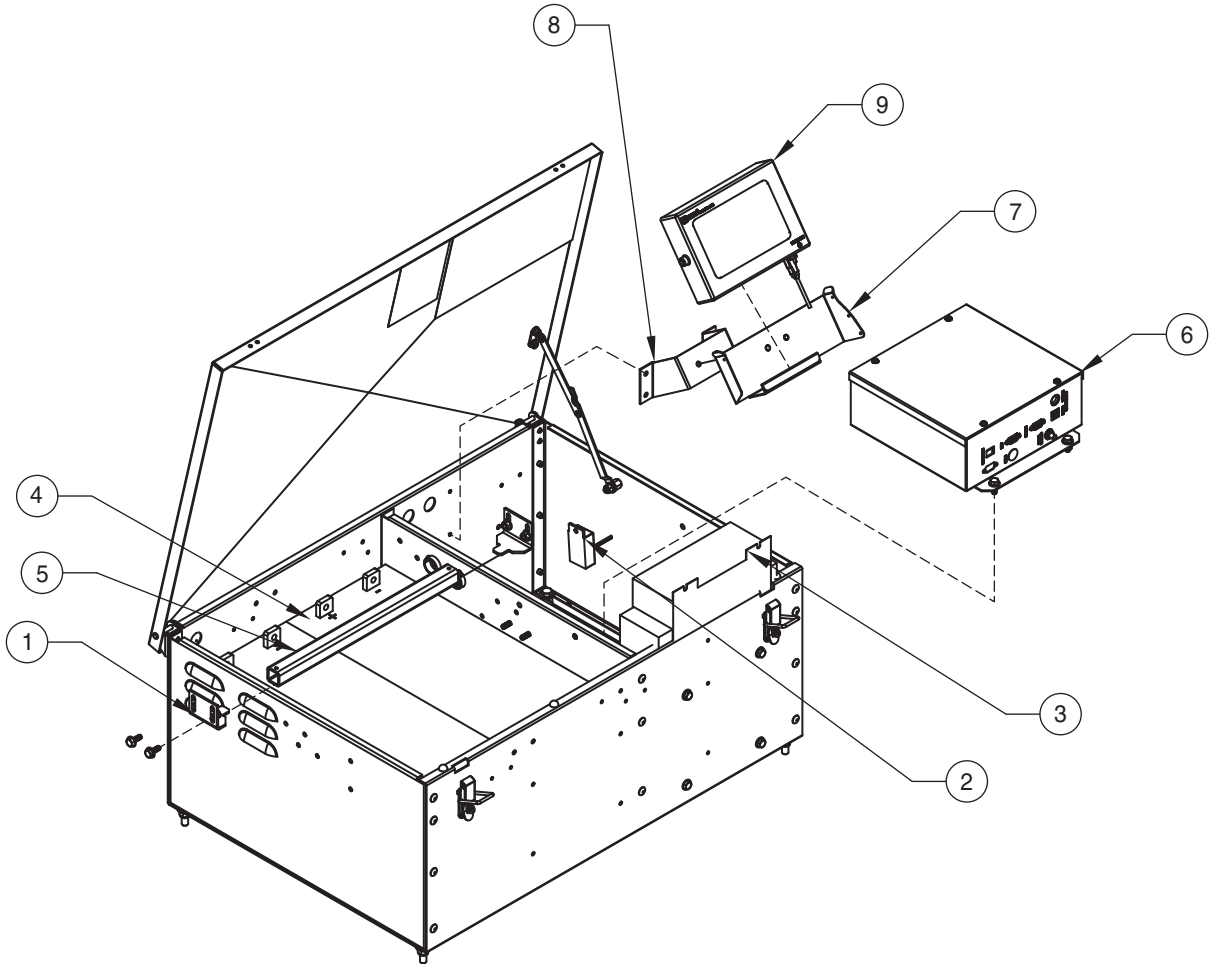
Figure 6-9. Replacement parts: battery box assembly

Item No.	Part No.	Description	Qty.
1	104577-001P2	BRKT,HLDN,BATT BX,CHNL RTNR,6V,BLK	2
2	202456	CHARGER, SMART,IQ,DUAL VOLTAGE JACK	1
3	203553	CHGR ASSY-BATT,15A 12VDC,MOD	1
4	205016	BATTERY, 12V, UB4DAGM	2
5	205019-P2	BATT HLD DWN,1" SQ. TUBE,14.63L,BLK	1
6	205441	COMPUTER BOX TRUCK MOUNT VMS	1
7	208926-P2	BRKT,MNT,TCH SCR,BATT BX,CMN,BLK	1
8	208927-P2	BRKT MTG,TCH SCR,BLK	1
9	209527-C1	CTRL ASSY,TSCRN,MB,USB,7	1



WANCO INC.

5870 Tennyson Street
Arvada, Colorado 80003

800-972-0755

303-427-5700

303-427-5725 fax

 www.wanco.com